

**Copyright Information**

Copyright © 2021 by SHENZHEN SMARTSAFE TECH CO.,LTD. All rights reserved. No part of this publication may be reproduced, stored in a retrieval system, or transmitted in any form or by any means, electronic, mechanical, photocopying, recording or otherwise, without the prior written permission of SMARTSAFE.

Neither SMARTSAFE nor its affiliates shall be liable to the purchaser of this unit or third parties for damages, losses, costs, or expenses incurred by purchaser or third parties as a result of: Accident, misuse, or abuse of this unit, or unauthorized modifications, repairs, or alterations to this unit, or failure to strictly comply with SMARTSAFE operating and maintenance instructions. SMARTSAFE shall not be liable for any damages or problems arising from the use of any options or any consumable products other than those designated as Original SMARTSAFE Products or SMARTSAFE Approved Products by SMARTSAFE.

All information, specifications and illustrations in this manual are based on the latest information available at the time of printing. SMARTSAFE reserves the right to make changes at any time without prior written or oral notice.

**Trademark Information**

**SmartSafe** is a registered trademark of SHENZHEN SMARTSAFE TECH CO.,LTD. in China and other countries. All other SMARTSAFE trademarks, service marks, domain names, logos, and company names referred to in this manual are either trademarks, registered trademarks, service marks, domain names, logos, company names of SMARTSAFE or are otherwise the property of SMARTSAFE or its affiliates. In countries where any of the SMARTSAFE trademarks, service marks, domain names, logos and company names are not registered, SMARTSAFE claims other rights associated with unregistered trademarks, service marks, domain names, logos, and company names. Other products or company names referred to in this manual may be trademarks of their respective owners. You may not use any trademark, service mark, domain name, logo, or company name of SMARTSAFE or any third party without permission from the owner of the applicable trademark, service mark, domain name, logo, or company name. You may contact SMARTSAFE by visiting the website at [www.newsmartsafe.com](http://www.newsmartsafe.com), or writing to SHENZHEN SMARTSAFE TECH CO.,LTD., 3310, Building 11, Tianan Cloud Park, Bantian Street, Longgang District, Shenzhen, Guangdong, China, to request written permission to use Materials on this manual for purposes or for all other questions relating to this manual.

## Contents

<b>1. Important Safety Instructions .....</b>	<b>1</b>
1.1 Important Notices .....	1
1.2 Qualified Personnel .....	1
1.3 Danger Notices .....	1
1.4 Training .....	2
1.5 Warning Signs .....	2
<b>2. Overview Of The Lift .....</b>	<b>3</b>
2.1 General Descriptions .....	3
2.2 Technical Data .....	3
2.3 Construction of the Lift .....	3
<b>3. Installation Instructions .....</b>	<b>4</b>
3.1 Preparations before installation .....	4
3.2 Precautions for installation .....	4
3.3 Installation .....	4
3.4 Items to be checked after installation .....	7
<b>4. Operation Instructions .....</b>	<b>7</b>
4.1 Precautions .....	7
4.2 Flow Chart for Operation .....	8
4.3 Operation Instructions .....	8
<b>5. Trouble Shooting .....</b>	<b>9</b>
<b>6. Maintenance .....</b>	<b>10</b>
6.1 Daily checking items before operation .....	10
6.2 Weekly checking items .....	10
6.3 Monthly checking items .....	10
6.4 Yearly checking items .....	11
<b>7. ANNEX .....</b>	<b>11</b>
Annex 1: Overall Diagram .....	11
Annex 2: Hydraulic working system .....	12
Annex 3: Assembly drawings .....	12
<b>Warranty .....</b>	<b>18</b>

# 1. Important Safety Instructions

## 1.1 Important Notices

SmartSafe will offer one-year's quality warranty for the whole machine , during which any quality problem will be properly solved to the user's satisfaction. However, we will not take any responsibility for whatever bad consequence resulted from improper installation and operation, overload running or unqualified ground condition.

This 2-posts lift is specially designed for lifting motor vehicles that weighs within its outmost lifting capacity. Users are not allowed to use it for any other purposes. Otherwise, we, as well as our sales agency, will not bear any responsibility for accidents or damages of the lift. Make sure to pay careful attention to the label of the lifting capacity attached on the lift and never try to lift cars with its weight beyond.

Read this manual carefully before operating the machine so as to avoid economic loss or personnel casualty incurred by wrong operation. Without our professional advice, users are not permitted to make any modification to the control unit or whatever mechanical unit.

## 1.2 Qualified Personnel

1.2.1 Only these qualified staff, who have been properly trained, can operate the lift.

1.2.2 Electrical connection must be done by a competent electrician.

1.2.3 People who are not concerned are not allowed in the lifting area.

## 1.3 Danger Notices

1.3.1 Do not install the lift on any asphalt surface.

1.3.2 Read and understand all safety warnings before operating the lift.

1.3.3 The lift, if is not specially designed upon customer's request, is not fit for outdoor use.

1.3.4 Keep hands and feet away from any moving parts. Keep feet clear of the lift when lowering.

1.3.5 Only these qualified people, who have been properly trained, can operate the lift.

1.3.6 Do not wear unfit clothes such as large clothes with flounces, tires, etc, which could be caught by moving parts of the lift.

1.3.7 To prevent evitable incidents, surrounding areas of the lift must be tidy and with nothing unconcerned.

1.3.8 The lift is simply designed to lift the entire body of vehicles, with its maximum weight within the lifting capacity.

1.3.9 Always insure the safety latches are engaged before any attempt to work near or under the vehicle.

1.3.10 Make sure to place the lifting pads to the positions as suggested by vehicle makers and when gradually lift the vehicle to the desired height, operators should be certain that the vehicle will not slant, roll-over or slide in lifting process.

1.3.11 Check at any time the parts of the lift to ensure the agility of moving parts and the performance of synchronization. Ensure regular maintenance and if anything abnormal occurs, stop using the lift immediately and contact our dealers for help.

1.3.12 Lower the lift to its lowest position and do remember to cut off the power source when service finishes.

1.3.13 Do not modify any parts of the lift without manufacturer’s advice.

1.3.14 If the lift is going to be left unused for a long time, users are required to:

- a. Disconnect the power source;
- b. Empty the oil tank;
- c. Lubricate the moving parts with hydraulic oil.

### 1.4 Training

Only these qualified people, who have been properly trained, can operate the lift. We are quite willing to provide professional training for the users when necessary.

*Note: For environment protection, please dispose the disused oil in a proper way.*

### 1.5 Warning Signs

All safety warning signs attached on the machine are for the purpose of drawing the user’s attention to safety operation. The labels must be kept clean and need to be replaced when they are worn-out or have dropped. Read the explanations of the labels carefully and try to memorize them.



## 2. Overview Of The Lift

### 2.1 General Descriptions

This machine composed of posts, carriages, lifting arms, cylinders and motor unit, etc.

It is driven by an electro-hydraulic system. The gear pump delivers hydraulic oil to oil cylinders and pushes upwards its piston. The piston drives the chain to raise the carriage and the lifting arms. During lifting process, the safety latch will automatically and firmly bite with the safety teeth block in the posts. Therefore, no slipping will happen in case the hydraulic system beaks down.

#### Safety Structure:

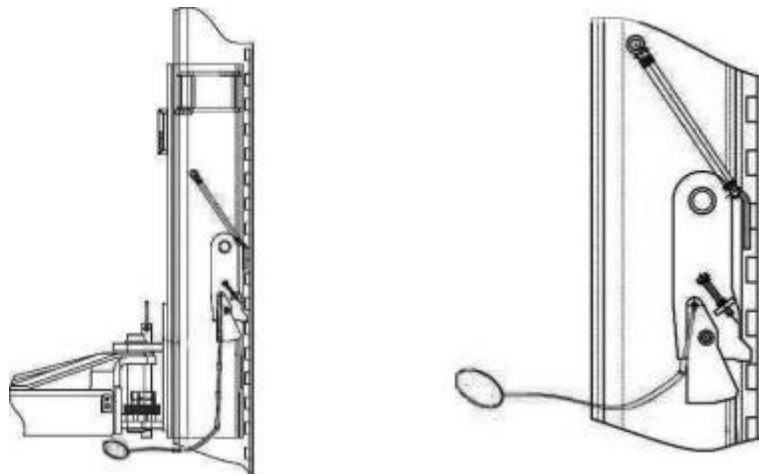

### 2.2 Technical Data

Model	Lifting capacity	Full rise time	Full Rise	Height	Width	Inside columns
LT245C	4500kg	45 Sec	1930mm	3852mm	3340mm	2980mm

### 2.3 Construction of the Lift

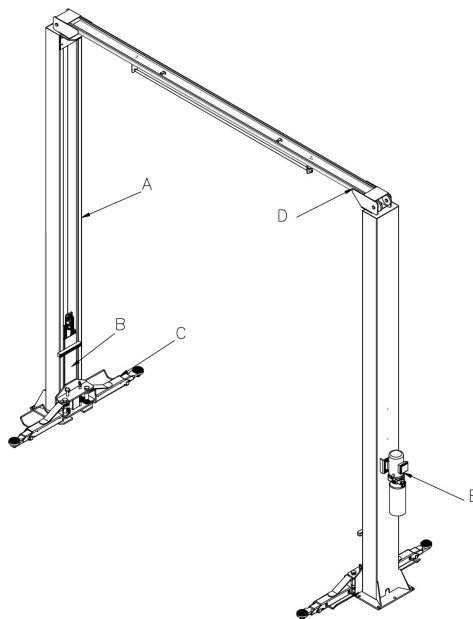

A	Column
B	Carriage
C	Lifting arm
D	Top beam
E	Power unit

## 3. Installation Instructions

### 3.1 Preparations before installation

#### 3.1.1 Tools and equipments needed

- ✓ Appropriate lifting equipment
- ✓ Anti-abrasion hydraulic oil.
- ✓ Rotary Hammer Drill with 3/4" drill bit.
- ✓ Chalk and tape measure, magnetic plump, 8 metersΦ15 level pipe.
- ✓ Sockets and open wrenches, a set of inside hex wrenches, cross and straight screw drivers.
- ✓ Hammer, 4pounds, sharp nose pliers, Φ17,Φ19,Φ22 socket spanners.

#### 3.1.2 Ground conditions

The lift should be fixed on a smooth and solid concrete ground with its strength more than 3000psi, tolerance of flatness less than 5mm and minimum thickness of 200mm. In addition, newly built concrete ground must undergo more than 28days' cure and reinforcement.

### 3.2 Precautions for installation

- 1) Make sure the two posts stand paralleled and are vertical to the ground. No slanting.
- 2) Joints of oil hose and steel cable must be firmly connected in order to avoid the looseness of steel cable and leakage of oil hose.
- 3) All bolts should be firmly screwed up.
- 4) Do not place any vehicle on the lift in the case of trial running.

### 3.3 Installation

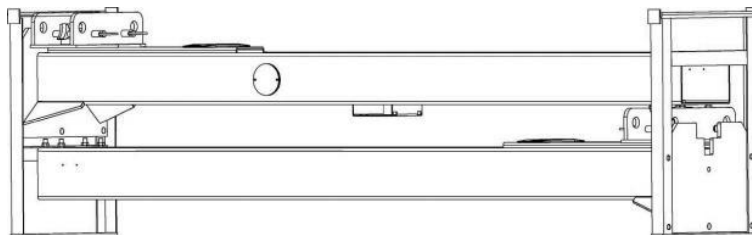

**Step 1:** Remove the packaging, take out the carton for accessories.

**Step 2:** Firstly, put something supporting between the two posts or suspend one of the posts by a crane and then remove the bolts from the package.

*Warning :* Please pay special attention not to let the post fall down for it may cause casualty or bring damages to the accessories fixed in the post.

**Step 3:** When the first post has been taken away, place something supporter under the second post and then remove the bolts from the package.

**Step 4:** Fix the standing position for the two posts.

- 1) Unfold the package and decide on which post the power unit will be mounted.

2) Draw an outline of the base plate on the ground with chalk and ascertain the position for the post.

**Step 5:** Erect the posts, power side post first and then the other post.

- 1) Drill anchor holes for expansion bolts on the ground with an electrical drill. Make sure to drill vertically.
- 2) After holes have been drilled, remove thoroughly the debris and dust in them and ascertain that the posts stay upon the circle previously drawn by chalk.

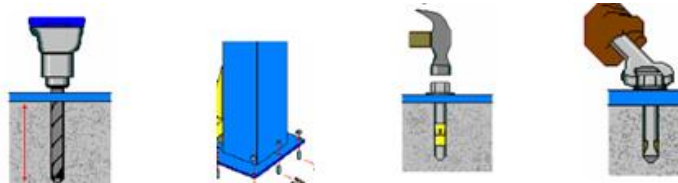

**Step6:** Connect steel cables.

- 1) Route and fix according to the following diagram of steel cable connection.
- 2) Raise carriages on both sides approximately 800mm above the ground. Carriages must be on the same height from the floor.
- 3) Make sure that the mechanical safety locks in each post are fully engaged before attempting to route cables.
- 4) After the cable being fixed, adjust and make the cable at both sides be with the same tightness which could be judged by the sound emitted during lifting process. Make judge and adjustment after trial running.
- 5) Grease after being fixed. (It is a must.)

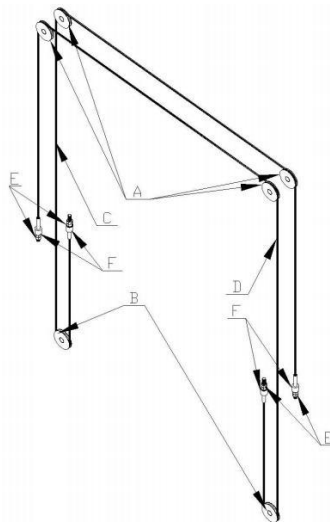

A	Top beam pulley
B	Base plate pulley
C	Steel cable 1
D	Steel cable 2
E	Wire rope boom seat post
F	M16 nut

**Step7:** Mount the power unit onto the power side post.

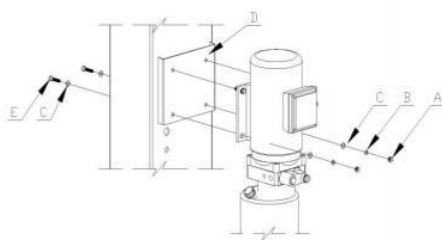

A	φ8 nuts
B	φ8 spring washer
C	φ8 flat washe
D	Motor hanging hole
E	M8×25 full thread hex flanges bolt

**Step 8:** Connect oil hoses.

Connect the oil hose as per the following diagram.

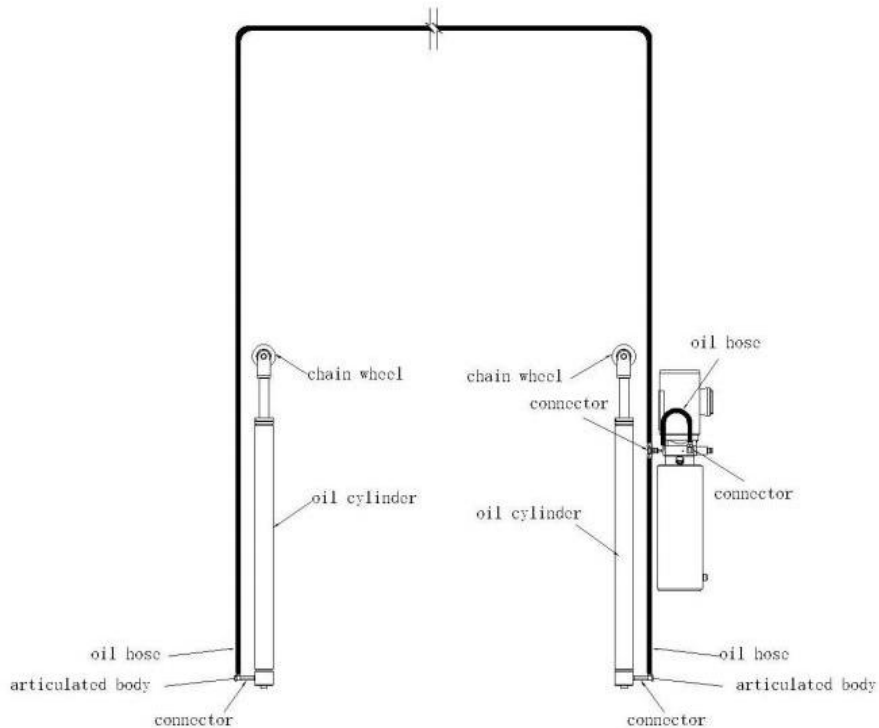

**Step9:** Install lifting arms.

Connect the lifting arms and the carriage by shafts.

Install the lifting arms onto the carriages and ensure the arm lock could work.

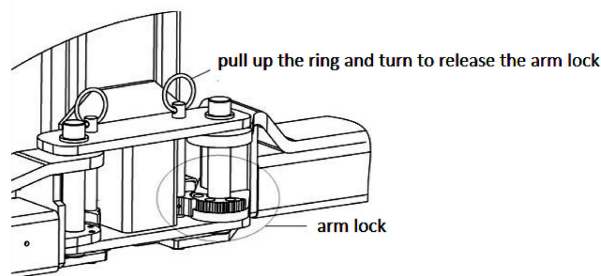

**Step10:** Fill with hydraulic oil.

The volume of oil tank is 10L. To insure the lift work normally, the amount of oil in it should at least reach 80% of the tank's total volume.

32# anti-abrasion hydraulic oil for winter, 46# for summer.

**Step11:** Trial running.

- 1) Do refer to the operation instructions in advance and keep in mind that no vehicle left on the lift in the process of trial running.
- 2) Check if mechanical locks can be well engaged or released in the running process. Adjust by screwing the hex head screw as showed in the following drawing in case the locks do not work well. (Screw clockwise in case the lock can not release and screw counterclockwise in case the lock can't



be engaged.)

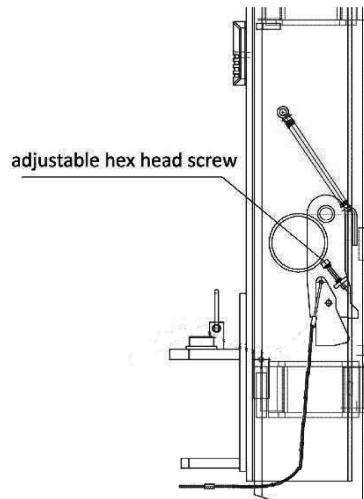

3) Check and ensure all the connections are in good condition.

4) No vehicle on the lift during trial running.

**3.4 Items to be checked after installation.**

No.	Check items	YES	NO
1	Are the posts vertical to the floor?		
2	Are the two posts paralleled?		
3	Is the oil hose well connected?		
4	Is the steel cable well connected?		
5	Are all lifting arms well fixed?		
6	Are electrical connections right?		
7	Are the rest joints firmly screwed?		
8	Are all items need lubricating added with grease?		

**4. Operation Instructions**

**4.1 Precautions**

- 1) Check all the joints of oil hose. Only when there is no leakage, the lift can start work.
- 2) The lift, if its safety device malfunctions, shall not be used.
- 3) The machine shall not lift or lower an automobile if its center of gravity is not positioned midway of the lifting arms. Otherwise, we as well as our dealers will not bear any responsibility for any consequence resulted thereby.
- 4) Operators and other personnel concerned should stand in a safety area during lifting and lowering process.
- 5) When lifting arms rise to the desired height, switch off the power at once to prevent any mal-operation done by unconcerned people.
- 6) Make sure the safety lock of the lift is engaged before start working under the vehicle and no people

under the vehicle during lifting and lowering process.

### 4.2 Flow Chart for Operation

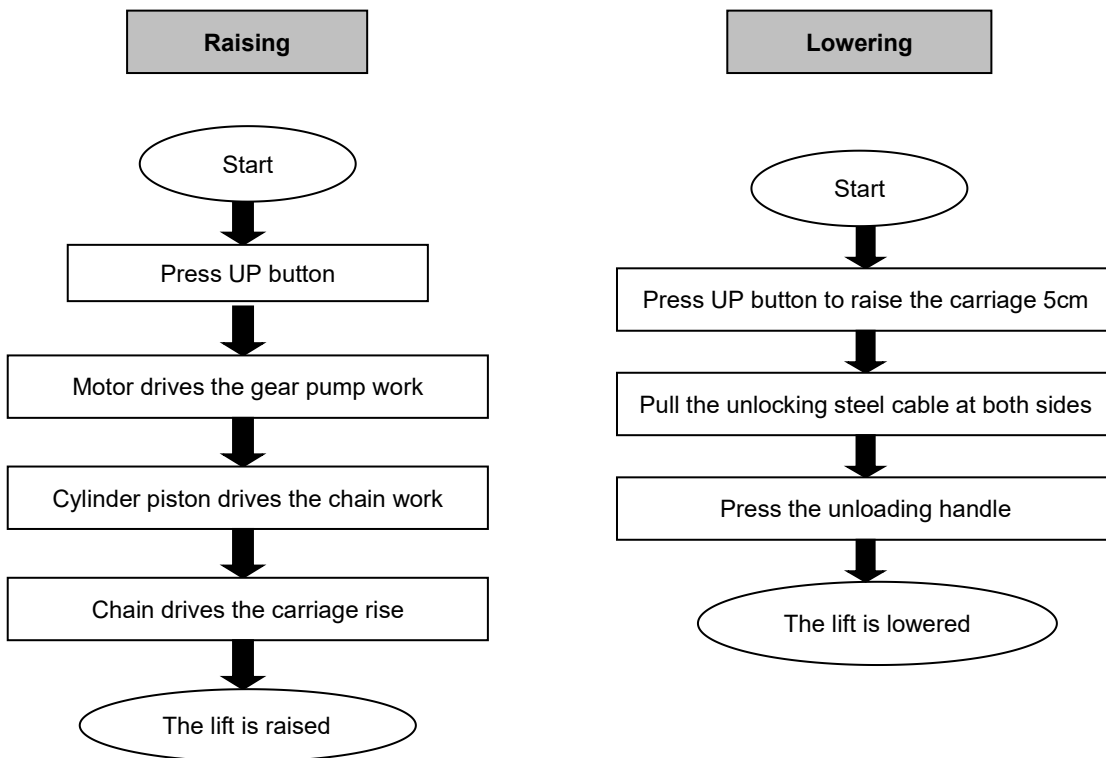

### 4.3 Operation Instructions

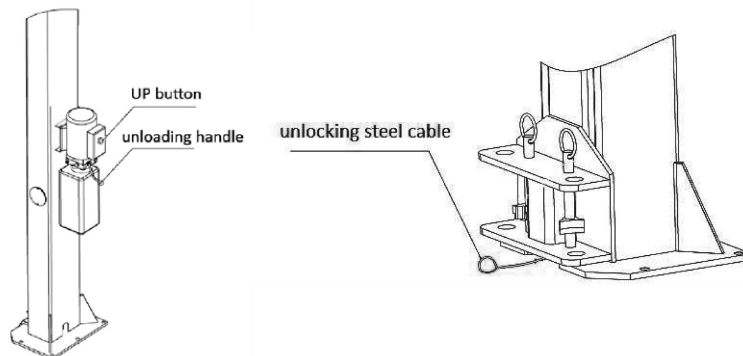

#### Raise the Lift

- 1) Make sure that you have read and understood the operation manual before operation.
- 2) Park the vehicle between two posts.
- 3) Adjust the lifting arms until they reach the supporting positions of the vehicle and make sure the gravity of vehicle located in the center of four lifting arms.
- 4) Connect the power supply as per requirements on the nameplate attached, and switch on.
- 5) Press the "UP" button on the control box until pads of lifting arms touched the prop-position of vehicle.
- 6) Keep on raising the vehicle to let it have a bit clearance from the ground and check again its stability.

7) Raise the vehicle to the desired height, check it is safe or not, press the “unlocking handle” button to have the safety locks engaged, and then perform maintenance or repair work underneath.

### Lower the Lift

- 1) Press the “UP” button on the control box to raise the lifting arms about 5CM which looses the safety lock.
- 2) Pull the unlocking steel cable at both sides to release the safety locks.
- 3) Press the unloading handle to lower the arms.
- 4) After the lifting arms lower to the lowest position, pull them out from under the vehicle and clear up all the obstacles.
- 5) Drive the vehicle away.

## 5. Trouble Shooting

*Note: If the trouble could not be fixed by yourself, please do not hesitate to contact us for help .We will offer our service at the earliest time we can. By the way, troubles could be judged and solved much faster if more details or pictures could be provided.*

Troubles	Cause	Solution
Abnormal noise	Abrasion exists on insider surface of the posts.	Grease the inside of the post.
	Trash in the post.	Clear the trash
Motor does not run and will not rise	The wire connection is loose.	Check and make a good connection.
	The motor is blown.	Replace it.
Motor runs but will not raise	The limit switch is damaged or the wire connection is loose.	Connect it or adjust or replace the limit switch.
	The motor run reversely.	Check the wire connection.
	Overflow valve is loose or jammed.	Clean or adjust it.
	The gear pump is damaged.	Replace it.
	Oil level is too low.	Add oil.
	The oil hose became loose or dropped off.	Tighten it.
Carriages go down slowly after being raised	The cushion valve became loose or jammed.	Clean or adjusts it.
	The oil hose leaks.	Check or replace it.
	The oil cylinder is not tightened.	Replace the seal.
	The single valve leaks.	Clean or replace it.
	E-magnetic valve fails to work well.	Clean or replace it.
Raising too slow	Steel cable is loose or not with same tightness	Check and adjust the tightness.
	The oil filter is jammed.	Clean or replace it.
	Oil level is too low.	Add oil.
	The overflow valve is not adjusted to the right position.	Adjust it.
	The hydraulic oil is too hot ( above 45° ) .	Change the oil.
	The seal of the cylinder is abraded.	Replace the seal.
Lowering too slow	Inside surface of the posts is not well greased.	Add grease.
	The throttle valve jammed.	Clean or replace.
	The hydraulic oil is dirty.	Change the oil.
	The anti-surge valve jammed.	Clean it.
The steel cable is abraded	The oil hose jammed.	Replace it.
	No grease when installation or out of lifetime	Replace it.

## 6. Maintenance

Easy and low cost routine maintenance can ensure the lift work normally and safely. Following are requirements for routine maintenance. Frequency of routine maintenance is determined by working condition and frequency.

### THE FOLLOWING PARTS ARE NEEDED TO BE LUBRICATED:

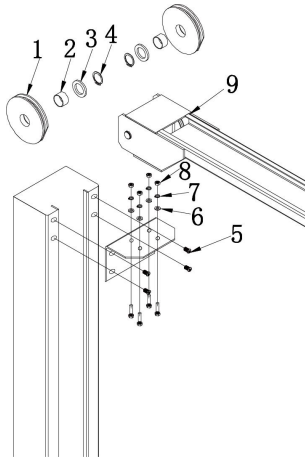

1	rope sheave
2	shaft sleeve
3	Φ25 gasket
4	Φ25 jump ring
5	Outer hexagonal screws M12x25
6	Φ12 flat pads
7	Φ12 spring washer
8	M12 nut
9	top beam

### 6.1 Daily checking items before operation

The user must perform daily check. Daily check of safety lock system is very important – the discovery of device failure before action could save time and prevent great loss, injury or casualty.

- Before operation, judge whether the safety locks are engaged by sound.
- Check whether oil hose well connected and whether it leaks or not.
- Check the connections of chain and steel cable and check the power unit.
- Check whether expansion bolts are firmly screwed.
- Check if arm lock works well or not.

### 6.2 Weekly checking items

- Check the flexibility of moving parts.
- Check the working conditions of safety parts.
- Check the amount of oil left in the oil tank. Oil is enough if the carriage can be raised to highest position. Otherwise, oil is insufficient.
- Check whether expansion bolts are firmly screwed.

### 6.3 Monthly checking items

- Check whether expansion bolts are firmly screwed.
- Check the tightness of the hydraulic system and screw firm the joints if it leaks.
- Check the lubrication and abrasion circumstance of axial pins, carriages, lifting arms and other related parts and replace in time with new ones if they failed to work well.
- Check the lubrication and abrasion circumstance of steel cable.

### 6.4 Yearly checking items

- Empty the oil tank and check the quality of hydraulic oil.
- Wash and clean the oil filter.

*Note: If users strictly follow the above maintenance requirements, the lift will keep in a good working condition and meanwhile accidents could be avoided to a large extent.*

## 7. ANNEX

### Annex 1: Overall Diagram

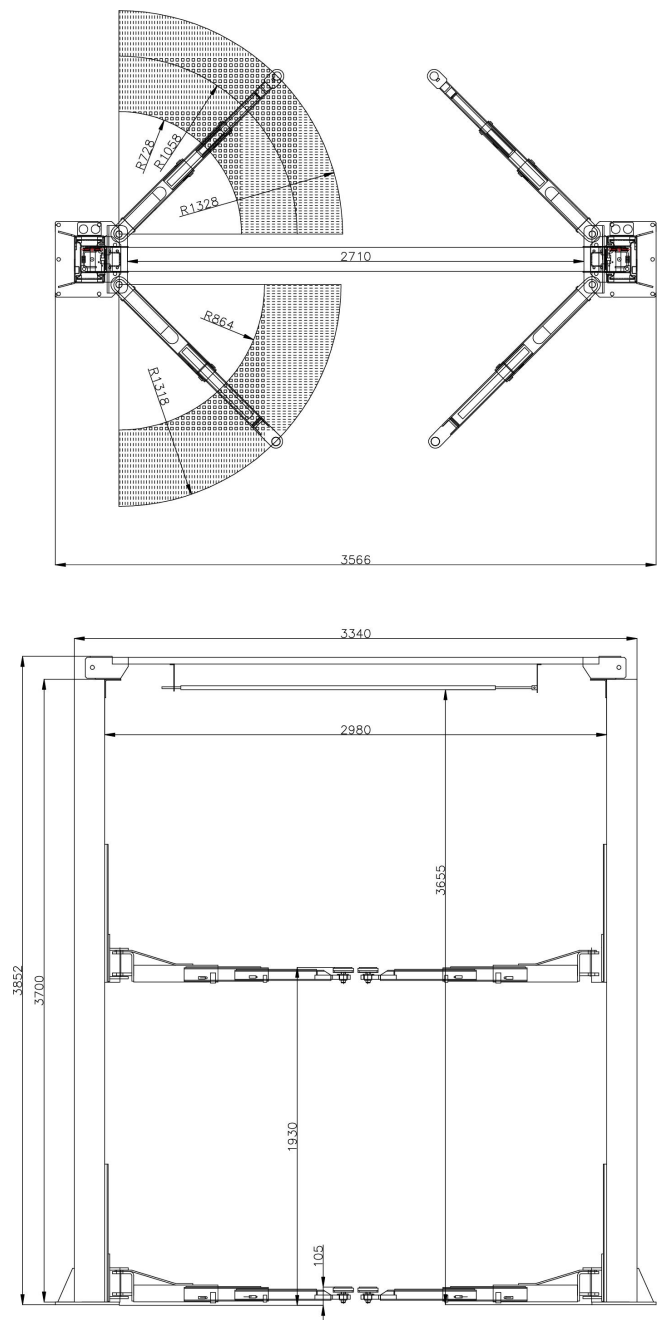

**Annex 2: Hydraulic working system**

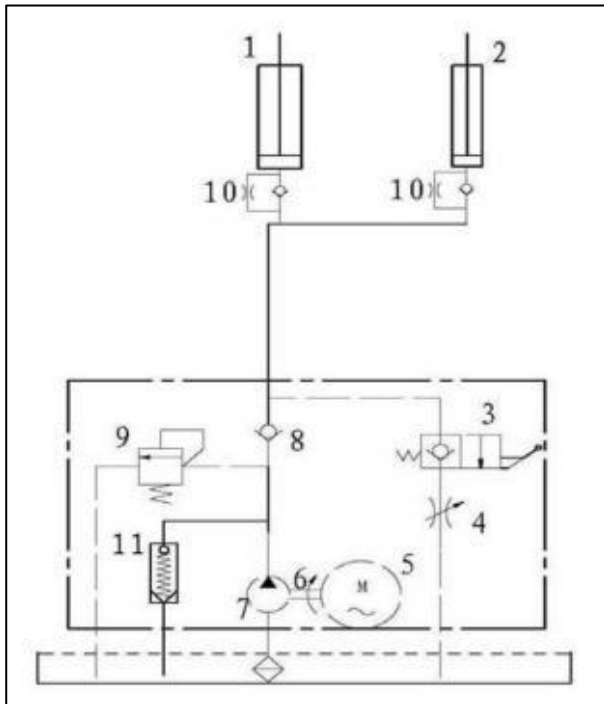

- 1. Drive oil cylinder
- 2. Assistant oil cylinder
- 3. Manual unloading valve
- 4. Throttle valve
- 5. Motor
- 6. Coupling
- 7. Gear pump
- 8. Single –way valve
- 9. Over-flow valve
- 10. Anti-surge valve
- 11. Cushion valve

**Annex 3: Assembly drawings**

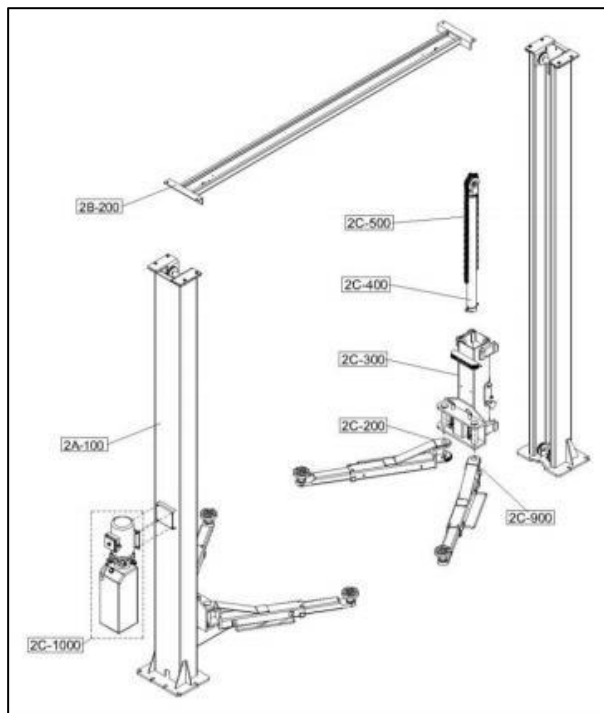

S/N	Name	Qty
2C-200	Complete lifting arm assembly	2 sets
2C-300	Complete carriage assembly	2 sets
2C-400	Complete oil cylinder	2 sets
2C-500	Chain	2 sets
2C-800	Complete control box assembly	1 set
Optional		
2C-900	Complete lifting arm assembly	2 sets
2A-100	Complete column assembly	2 sets
2B-200	Complete top beam assembly	1 set

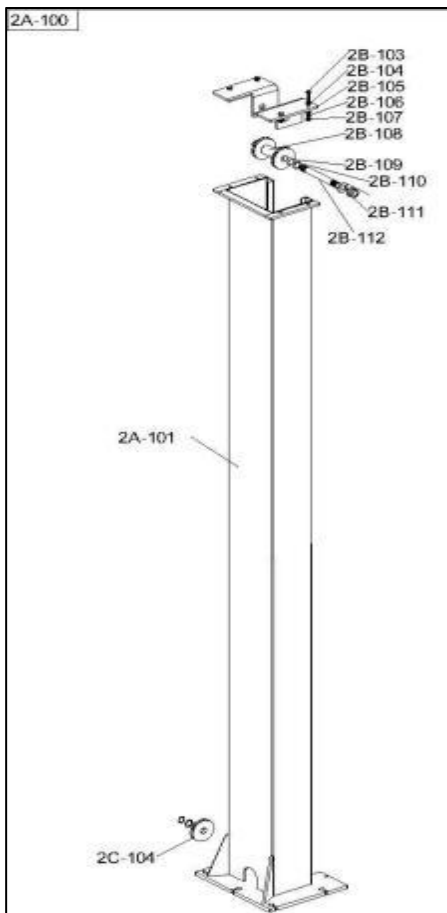

S/N	Name	Qty
2C-104	Pulley	3 pcs
2A-101	Column	2 pcs
2B-102	Extendable column	2 pcs
2B-103	Hex screw M10*30	4 pcs
2B-104	Flat washer Ø 12	8 pcs
2B-105	Top plate	2 pcs
2B-106	Spring washer Ø 12	4 pcs
2B-107	Hex nut M12	4 pcs
2B-108	Sleeve	1 pc
2B-109	Axle sleeve	2 pcs
2B-110	Flat washer Ø 25	2 pcs
2B-111	Hex nut M20	2 pcs
2B-112	Fixed axis	1 pc

S/N	Name	Qty
2B-201	Top plate	1 pc
2B-202	Limited switch	1 pc
2B-203	Fixed base 1	1 pc
2B-204	Round steel tube	1 pc
2B-205	Fixed base 2	1 pc

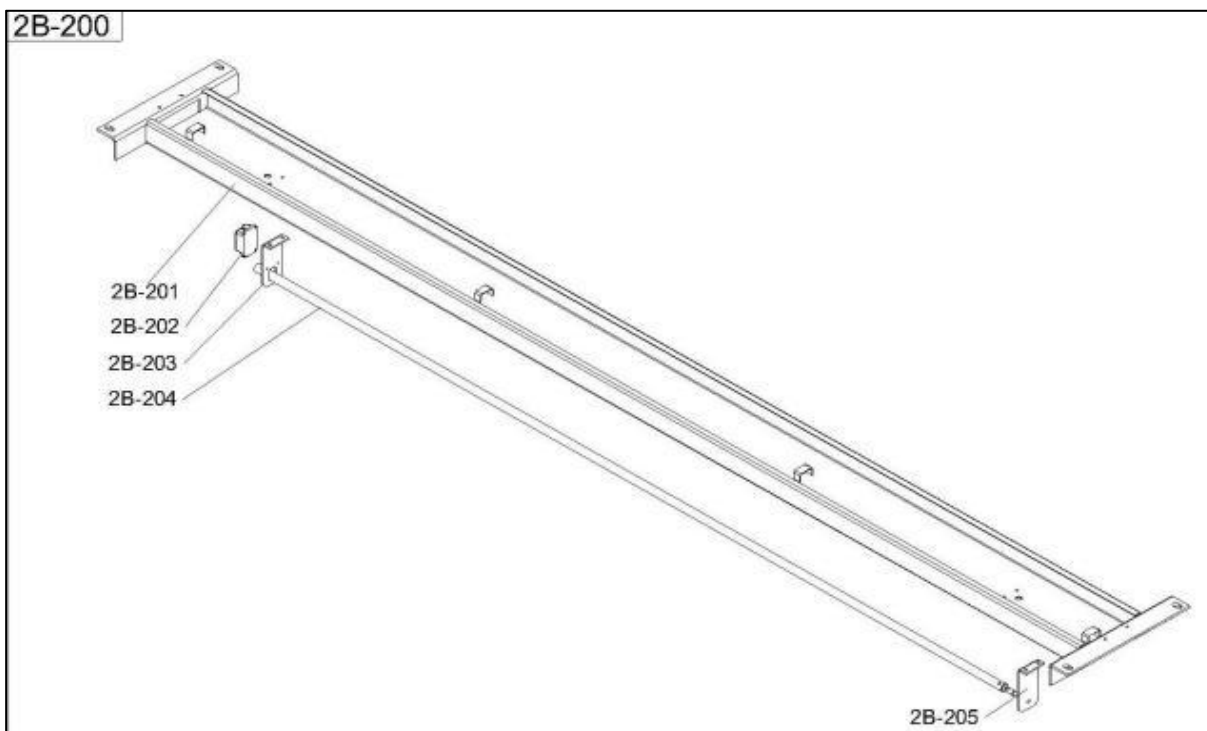

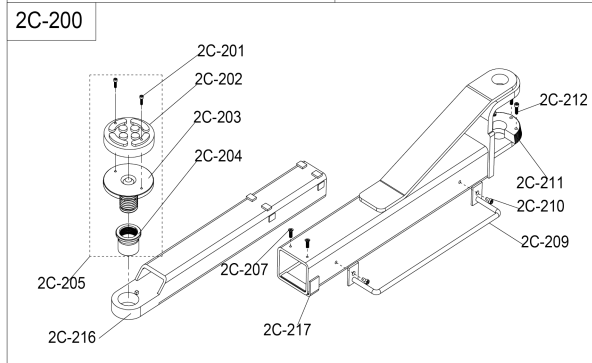
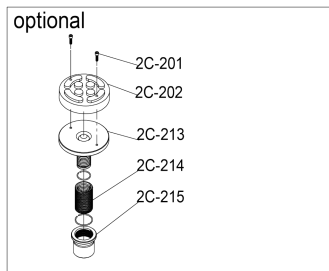

S/N	Name	Qty
2C-201	Cross countersunk head screw M8*16	8 pcs
2C-202	Rubber lifting pad 120*30mm	4 pcs
2C-203	Lifting tray	4 pcs
2C-204	Swivel nut	4 pcs
2C-205	Complete tray assembly (2C-201,202,203,204)	4 sets
2C-216	Lifting arm1 80*80*580mm	2 pcs
2C-207	Cross socket head cap screw M8*12	8 pcs
2C-217	Lifting arm2 100*100*575mm	2 pcs
2C-209	Fender	4 pcs
2C-210	Hex socket head cap screw M8	8 pcs
2C-211	Semi-circle block	4 pcs
2C-212	Hex socket head cap screw M8*12	12 pcs
2C-213	Inside swivel nut	4 pcs
2C-214	Swivel nut	4 pcs

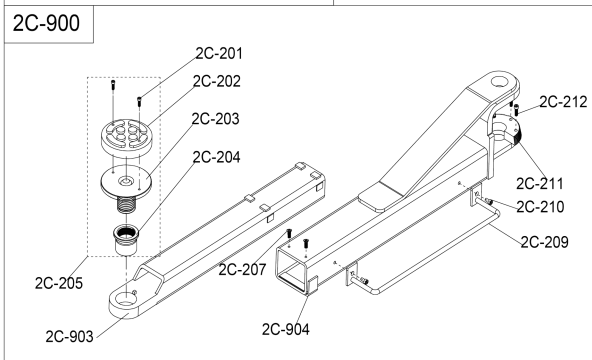
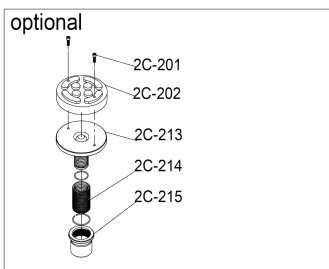

S/N	Name	Qty
2C-903	Lifting arm3 80*80*630mm	2 pcs
2C-904	Lifting arm4 100*100*625mm	2 pcs



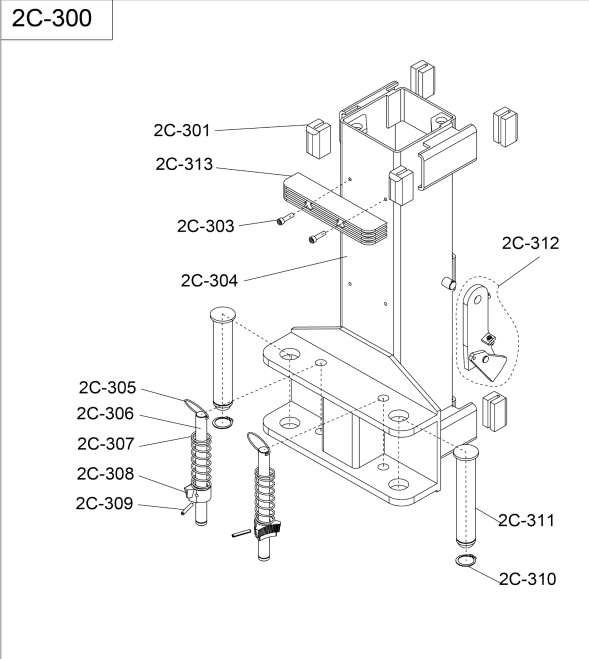

S/N	Name	Qty
2C-301	Slider 70*37*37mm	16 pcs
2C-313	Protection rubber pad	2 pcs
2C-303	Hex socket head cap screw M8	4 pcs
2C-304	Carriage	2 pcs
2C-305	Key ring Ø 4*60	4 pcs
2C-306	Locking shaft Ø 22	4 pcs
2C-307	Spring	4 pcs
2C-308	Teeth block	4 pcs
2C-309	Elastic cylindrical pin	4 pcs
2C-310	Shaft snap ring Ø 40	4 pcs
2C-311	Pin shaft	4 pcs
2C-312	Insurance device	1 set

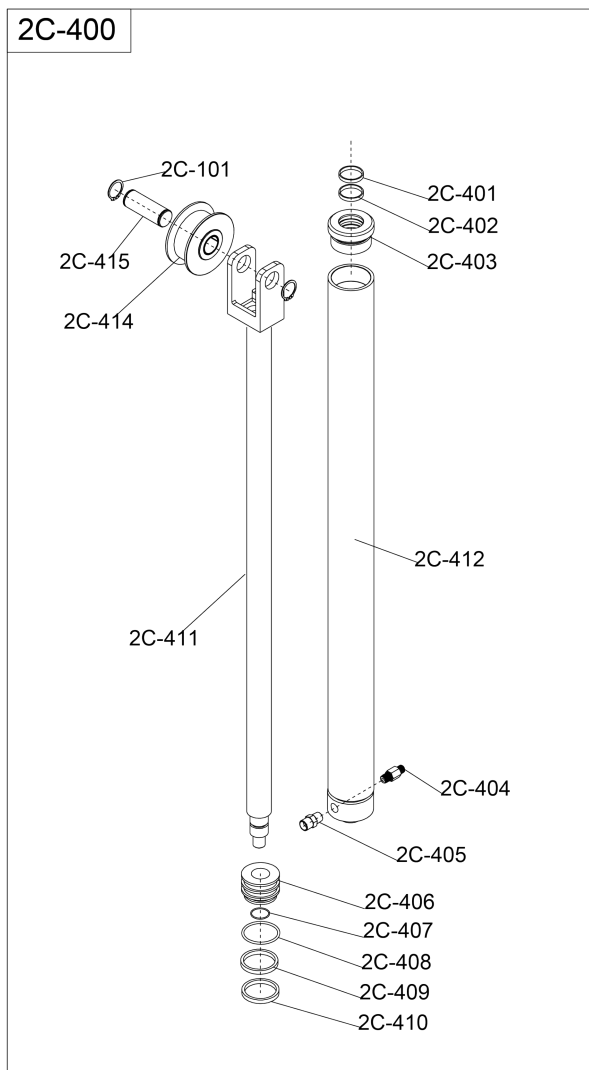

S/N	Name	Qty
2C-401	Y-ring 48*6mm	2 pcs
2C-402	Guided ring 44*10mm	2 pcs
2C-403	Oil cylinder cover	2 pcs
2C-404	Oil hose connector	1 pc
2C-405	Oil hose connector	2 pcs
2C-406	Piston	2 pcs
2C-407	O-ring 25*4mm	2 pcs
2C-408	O-ring 64*5.5mm	2 pcs
2C-409	Guided ring 63*9.2mm	2 pcs
2C-410	Y-ring 63*10mm	2 pcs
2C-411	Piston rod	2 pcs
2C-412	Oil cylinder	2 pcs
2C-414	Chain wheel	2 pcs
2C-415	Shaft	2 pcs
2C-101	Shaft snap ring Ø 30	4 pcs

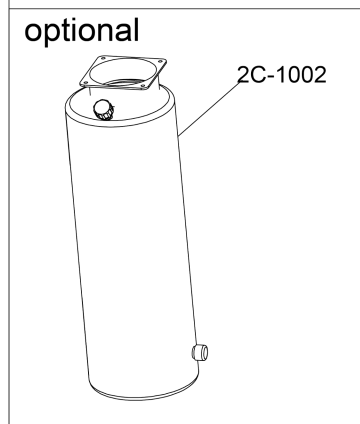
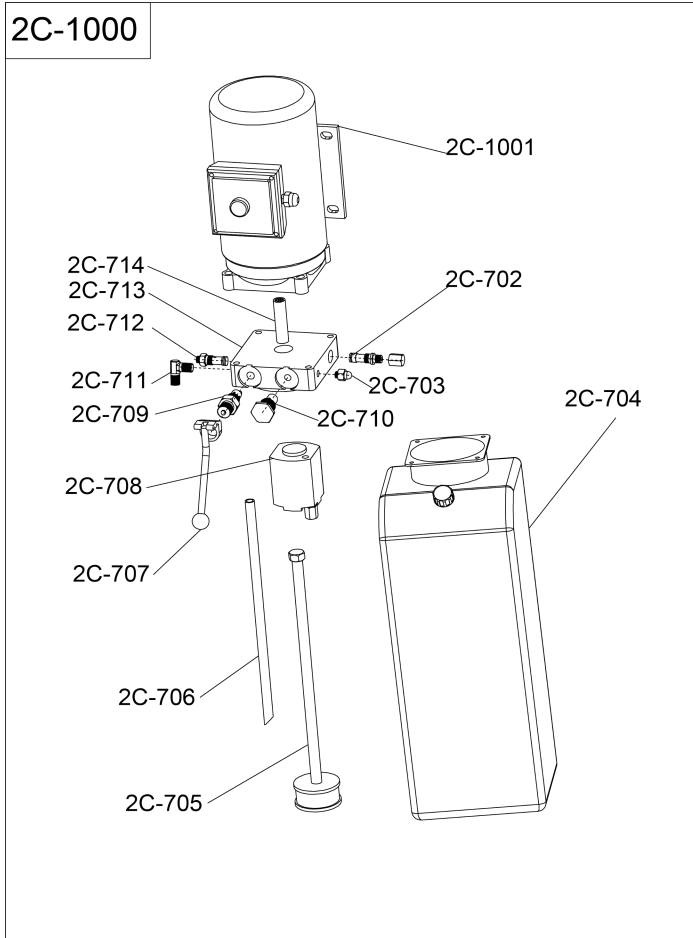

S/N	Name	Qty
2C-1001	Motor	1 pc
2C-702	Overflow valve	1 pc
2C-703	Plug	1 pc
2C-704	Plastic oil tank	1 pc
2C-705	Oil absorbing pipe	1 pc
2C-706	Oil back pipe	1 pc
2C-707	Lowering handle	1 pc
2C-7082C-7	Gear pump	1 pc
2C-709	Unloading valve	1 pc
2C-710	One-way valve	1 pc
2C-711	Oil hose connector	1 pc
2C-712	Throttle valve	1 pc
2C-713	Valve seat	1 pc
2C-714	Annectent spinde	1 pc
2C-1002	Iron oil tank (optional)	1 pc

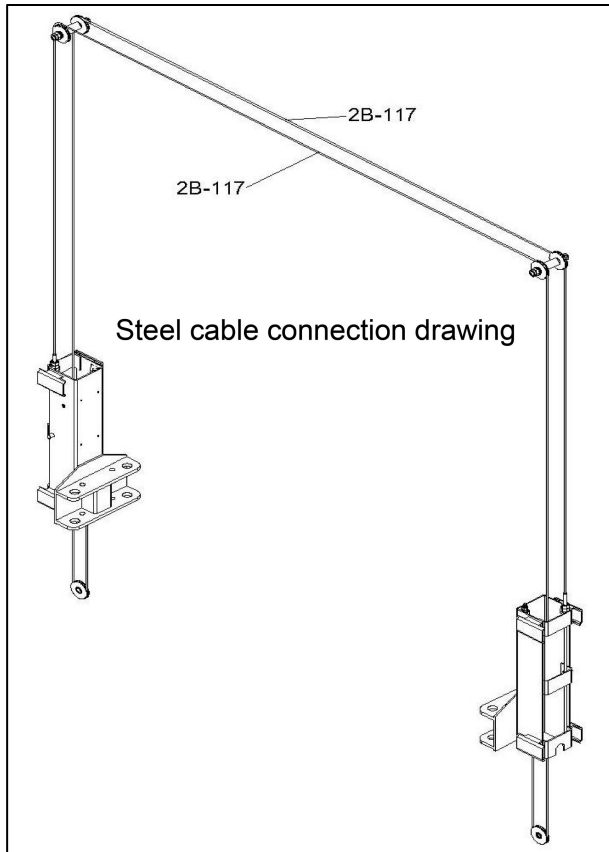

S/N	Name	Qty
2B-117	Steel cable	2 pcs

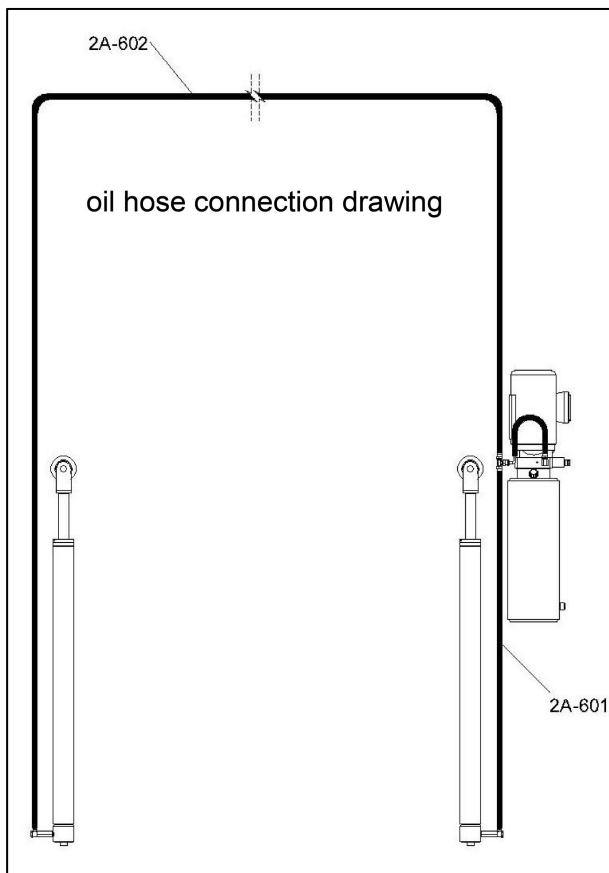

S/N	Name	Qty
2A-601	Short oil hose	1 pc
2A-602	Long oil hose	1 pc

**Warranty**

THIS WARRANTY IS EXPRESSLY LIMITED TO PERSONS WHO PURCHASE SMARTSAFE PRODUCTS FOR PURPOSES OF RESALE OR USE IN THE ORDINARY COURSE OF THE BUYER'S BUSINESS.

SMARTSAFE electronic product is warranted against defects in materials and workmanship for one year from date of delivery to the user.

This warranty does not cover any part that has been abused, altered, used for a purpose other than for which it was intended, or used in a manner inconsistent with instructions regarding use. The exclusive remedy for any automotive meter found to be defective is repair or replacement, and SMARTSAFE shall not be liable for any consequential or incidental damages.

Final determination of defects shall be made by SMARTSAFE in accordance with procedures established by SMARTSAFE. No agent, employee, or representative of SMARTSAFE has any authority to bind SMARTSAFE to any affirmation, representation, or warranty concerning SMARTSAFE automotive meters, except as stated herein.

**Disclaimer**

The above warranty is in lieu of any other warranty, expressed or implied, including any warranty of merchantability or fitness for a particular purpose.

**Purchase Order**

Replaceable and optional parts can be ordered directly from your SMARTSAFE authorized dealer. Your order should include the following information:

- Order quantity
- Part number
- Part name

**Customer Service Center**

Customer Service Center

For any problem met during the operation, please call +86-755-89589810.

If the device needs to be repaired, please send it back to SmartSafe, and attach the Warranty Card, Product Qualification Certificate, Purchase Invoice and problem description. SmartSafe will maintain and repair the device for free when it is within warranty period. If it is out of warranty, SmartSafe will charge the repair cost and return freight.

SmartSafe address:

3310, Building 11, Tianan Cloud Park, Bantian Street, Longgang District, Shenzhen, Guangdong, China

Zip code: 518110

Website: <http://www.newsmartsafe.com>

**Statement:**

SMARTSAFE reserves the rights to make any change to product designs and specifications without notice. The actual object may differ a little from the descriptions in the manual in physical appearance, color and configuration. We have tried our best to make the descriptions and illustrations in the manual as accurate as possible, and defects are inevitable, if you have any question, please contact local dealer or after-sale service center of SMARTSAFE, SMARTSAFE does not bear any responsibility arising from misunderstandings.