

SmartSafe

LT640

Ultra-thin Small Scissor Lift

User Manual

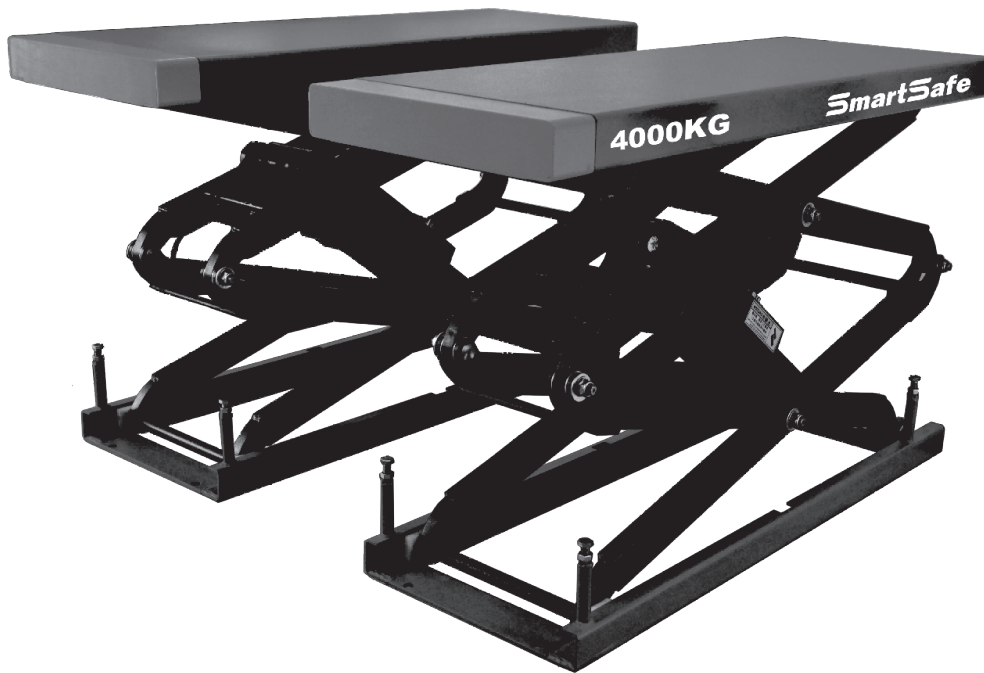

WARNING

Read this material before using this product.
Failure to do so can result in serious injury.

Copyright Information

Copyright © 2024 by SHENZHEN SMARTSAFE TECH CO.,LTD. All rights reserved. No part of this publication may be reproduced, stored in a retrieval system, or transmitted in any form or by any means, electronic, mechanical, photocopying, recording or otherwise, without the prior written permission of SMARTSAFE.

Neither SMARTSAFE nor its affiliates shall be liable to the purchaser of this unit or third parties for damages, losses, costs, or expenses incurred by purchaser or third parties as a result of: Accident, misuse, or abuse of this unit, or unauthorized modifications, repairs, or alterations to this unit, or failure to strictly comply with SMARTSAFE operating and maintenance instructions. SMARTSAFE shall not be liable for any damages or problems arising from the use of any options or any consumable products other than those designated as Original SMARTSAFE Products or SMARTSAFE Approved Products by SMARTSAFE.

All information, specifications and illustrations in this manual are based on the latest information available at the time of printing. SMARTSAFE reserves the right to make changes at any time without prior written or oral notice.

Trademark Information

SmartSafe is a registered trademark of SHENZHEN SMARTSAFE TECH CO.,LTD. in China and other countries. All other SMARTSAFE trademarks, service marks, domain names, logos, and company names referred to in this manual are either trademarks, registered trademarks, service marks, domain names, logos, company names of SMARTSAFE or are otherwise the property of SMARTSAFE or its affiliates. In countries where any of the SMARTSAFE trademarks, service marks, domain names, logos and company names are not registered, SMARTSAFE claims other rights associated with unregistered trademarks, service marks, domain names, logos, and company names. Other products or company names referred to in this manual may be trademarks of their respective owners. You may not use any trademark, service mark, domain name, logo, or company name of SMARTSAFE or any third party without permission from the owner of the applicable trademark, service mark, domain name, logo, or company name. You may contact SMARTSAFE by visiting the website at www.newsmartsafe.com, or writing to SHENZHEN SMARTSAFE TECH CO.,LTD., 3310, Building 11, Tianan Cloud Park, Bantian Street, Longgang District, Shenzhen, Guangdong, China, to request written permission to use Materials on this manual for purposes or for all other questions relating to this manual.

Safety Precautions

- Make sure that you have read the User 's Manual completely including relevant instructions on installation, operation and safety before operating the lift.
- Do not use the lift if any abnormality is found in the lift.
- Do not overload the lift beyond its rated load 4000KG.
- The lift can be operated by trained personnel only. The vehicle customer or the inexperienced person is prohibited from operating the lift at will.
- The rubber pad of the small scissor lift must have contact with the support point of the vehicle, otherwise the vehicle chassis may be damaged. (It is recommended to consult the vehicle manufacturer by telephone if the location of the support point is not clear.)

- Be sure to perform mechanical locking after the vehicle is lifted. It is forbidden to work under the vehicle before mechanical locking is performed.
- Keep the area around the lift clean and tidy as any oil stain or obstacle may pose a safety risk.
- Never lift the vehicle with people in it.
- Make sure there is no obstacle under the vehicle before lowering it.
- It is prohibited to remove any hydraulic component when the hydraulic system is under pressure.
- Do not put hands at any dangerous place, such as the space between tool arms.
- It is prohibited to use the product outdoors as it is only suitable for indoor use.
- Press and hold the Down button while lowering, so the platforms ascend a little automatically to open the safety lock, and then descend automatically.
- Always wear safety shoes during operation.
- It is forbidden to lift the vehicle when someone is in the vehicle.
- Cut off the power supply after the use of lift.
- When a vehicle is being loaded onto or unloaded from the lift, no person is allowed to stand in the vehicle passage.
- Ensure that the platforms of main and sub lifts are lowered to the lowest positions before the vehicle departs from/leaves the lift.
- Use wedge blocks to lock the vehicle so that the vehicle cannot move.
- Read the operation warning label carefully and thoroughly.

Contents

- 1. Product Features and Parameters 1**
 - 1.1 Product features 1
 - 1.2 Technical parameters 1
 - 1.3 Schematic diagram for main components 4
- 2. Preparation for Installation 5**
 - 2.1 Unpacking 5
 - 2.2 Preparation for installation 6
 - 2.3 Installation 7
- 3. Commissioning 13**
- 4. Maintenance 14**
 - 4.1 Maintenance 14
 - 4.2 Operation cautions 14
 - 4.3 Electrical operation instructions 15
 - 4.4 Oil-filling and leveling 16
 - 4.5 Emergency manual lowering procedures at power failure 16
- 5. Exploded Views 18**
- Warranty 20**

1. Product Features and Parameters

1.1 Product features

- Movable ramp which can be used as extension board
- Monolithic baseplate without splice
- Stable and reliable control system
- Aluminum alloy motor with low noise and fast heat dissipation.

1.2 Technical parameters

Rated lifting capacity	4000kg
Initial height	330mm
Lifting height	1999mm
Platform length	1560-1760mm
Platform width	565mm
Motor parameters	3PH, 380VAC, 3KW
	1PH, 220VAC, 3KW
Type of hydraulic oil	ISO 46#
Air pressure	0.6-0.8MPa

Diagram of product:

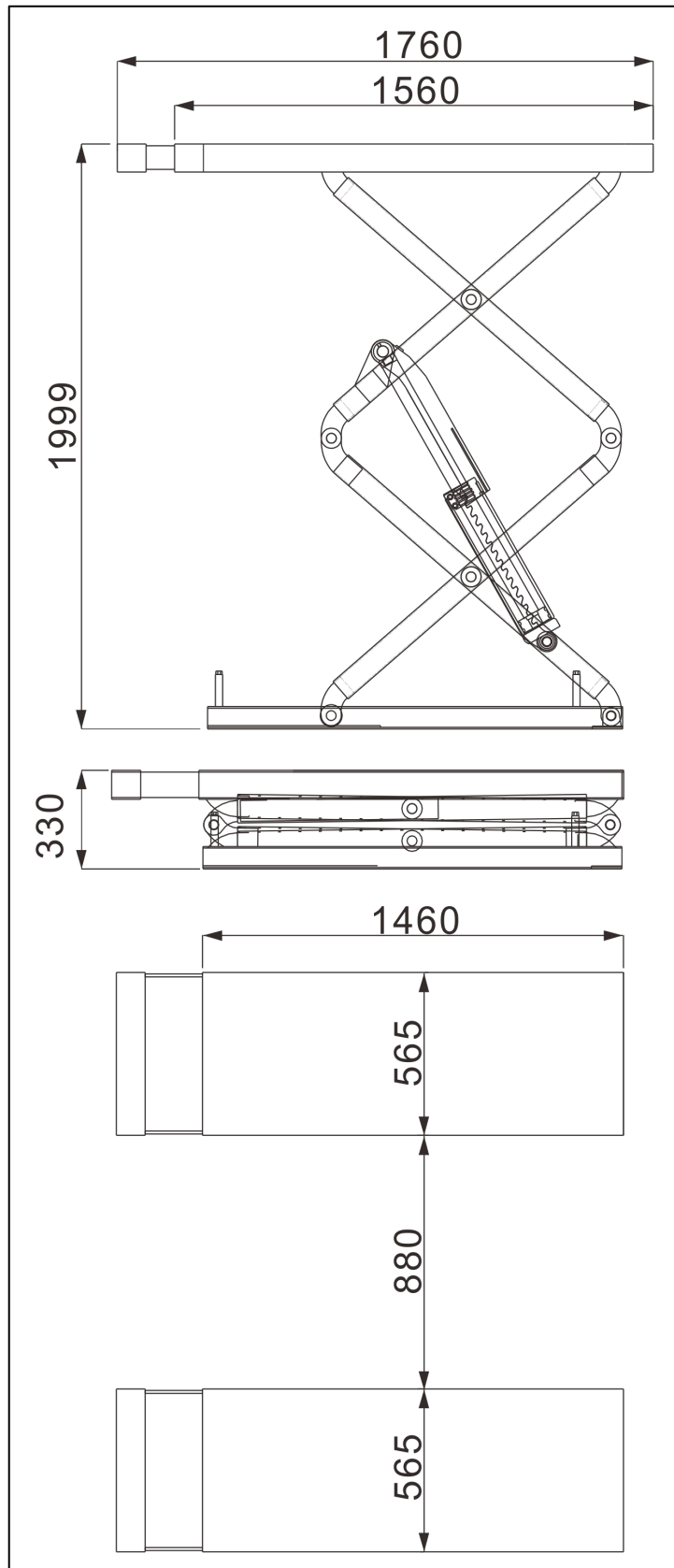

Fig. 1

Electrical diagram:

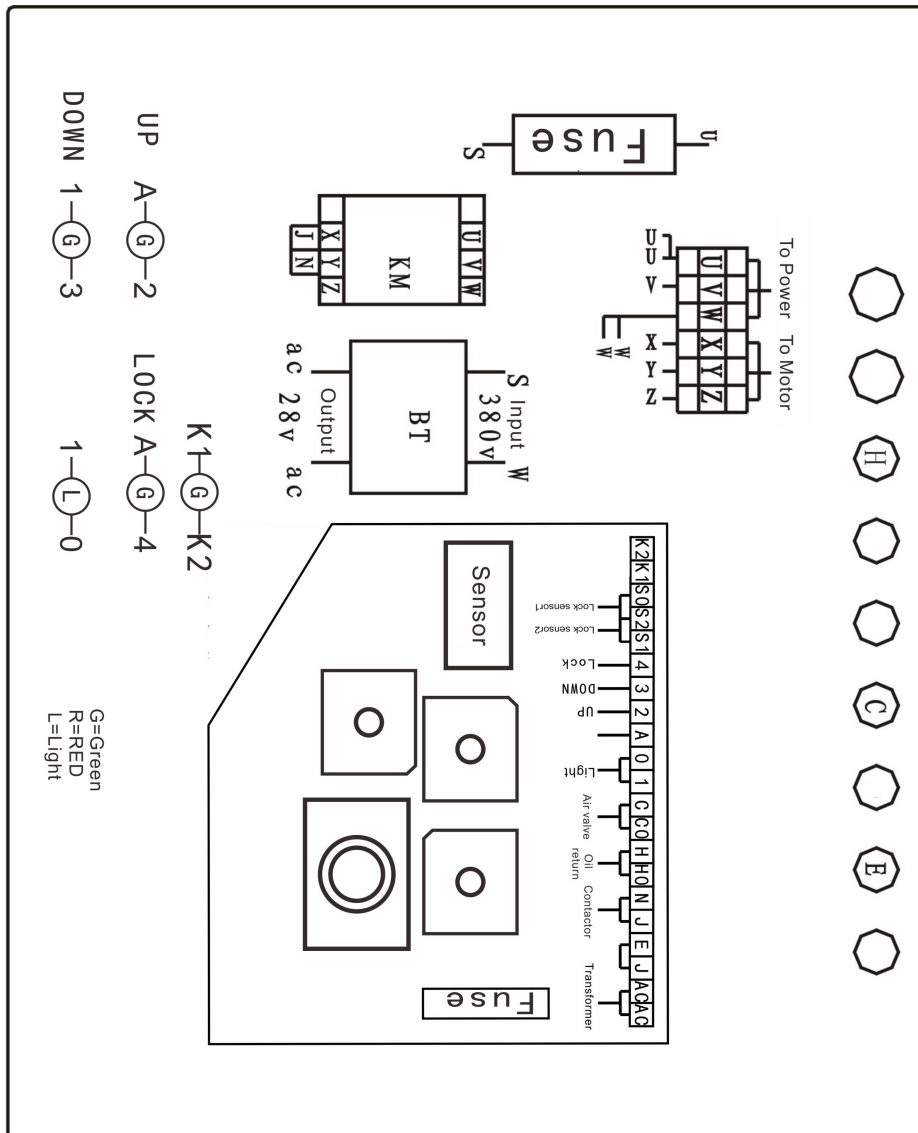

Fig. 2

No.	Code	Name	Specification	Quantity	Remarks
1	QS	Automatic air switch	C63	1	Retrofitted by the user
2	CK	AC contactor	CJX2-1201	1	
3	HL	Power Indicator	AD130	1	
4	SA1	UP button	Y090 10	1	
5	SA2	DOWN button	Y090 20	1	
6	SA3	Lock button	Y090 10	1	
7	YV	Oil return valve	24V-50HZ	1	Supplied in hydraulic station
8	M	AC motor	3KW/50HZ	1	

1.3 Schematic diagram for main components

Working platform	For lifting the vehicle by contacting the chassis.
Safety gear rack	Safety mechanism for mechanical locking.
Cylinder	Actuator, pushing the platform to rise.
Extractable arm	Extension work platform.
Master cylinder	Actuator, pushing the platform to rise, with two oil pipes.
Slave cylinder	Actuator, pushing the platform to rise, with one oil pipe.
Scissor arm	Main lifting structure.

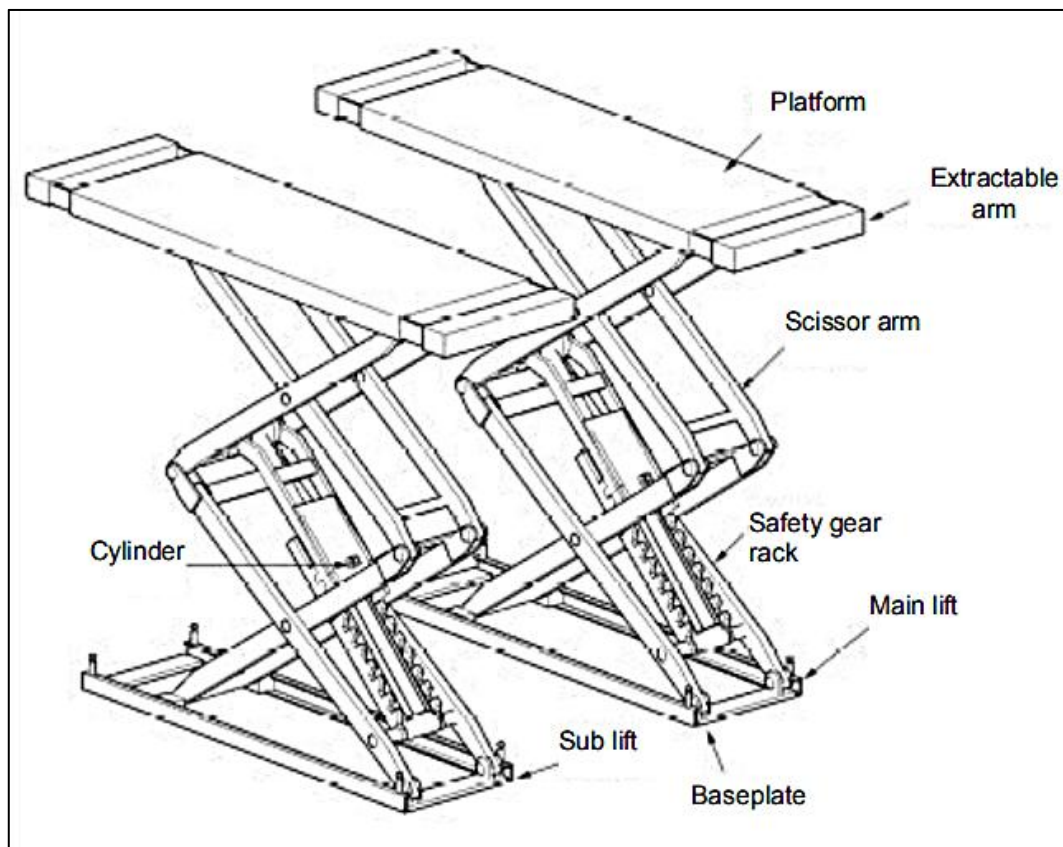

Fig. 3

2. Preparation for Installation

2.1 Unpacking

All packing, loading/unloading, transportation and unpacking operations must be performed by professional personnel.

Transportation:

The scissor lift shall be loaded/unloaded and moved by a lifting machine and forklift with capacity over 3 tons. To prevent the scissor lift falling off, one person shall pay attention to the scissor lift during the lifting operation for fear of accidents. The scissor lift shall be transported by an automobile or ship. The scissor lift shall be inspected for completeness when it arrives, for fear of damage or loss during transportation.

If the packing box is broken during transportation, inspect the broken box according to the Packing List, confirm the damaged articles and lost components, and at the same time, inform the carrier immediately.

The lift is heavy! Therefore, manpower loading/unloading and handling are forbidden. Safety is of much importance. In addition, the hoisting of scissor lift during loading/unloading shall be operated as illustrated.

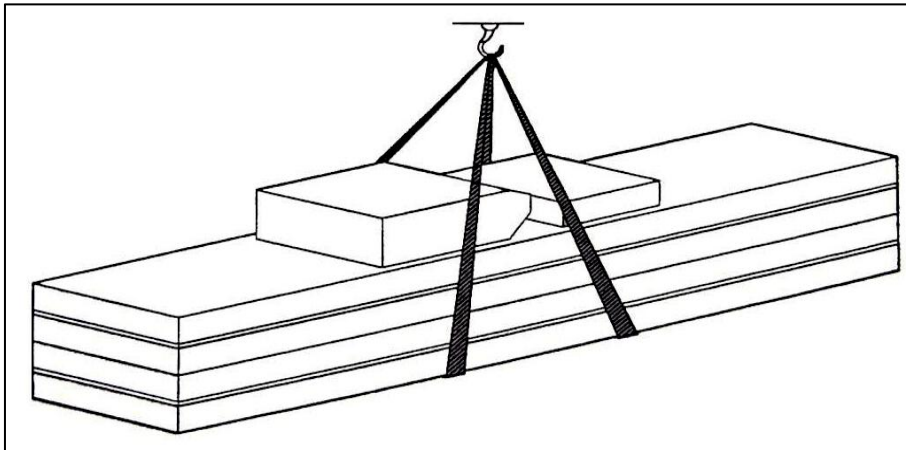

Fig. 4

Storage:

Machinery equipment shall be stored in an indoor warehouse, and waterproof treatment shall be adopted in case of outdoor storage. A van truck shall be used for highway transportation, and a container for waterway transport. The control cabinet must be placed upright during transportation, and be protected from squeezing by other goods.

2.2 Preparation for installation

Installation scheme

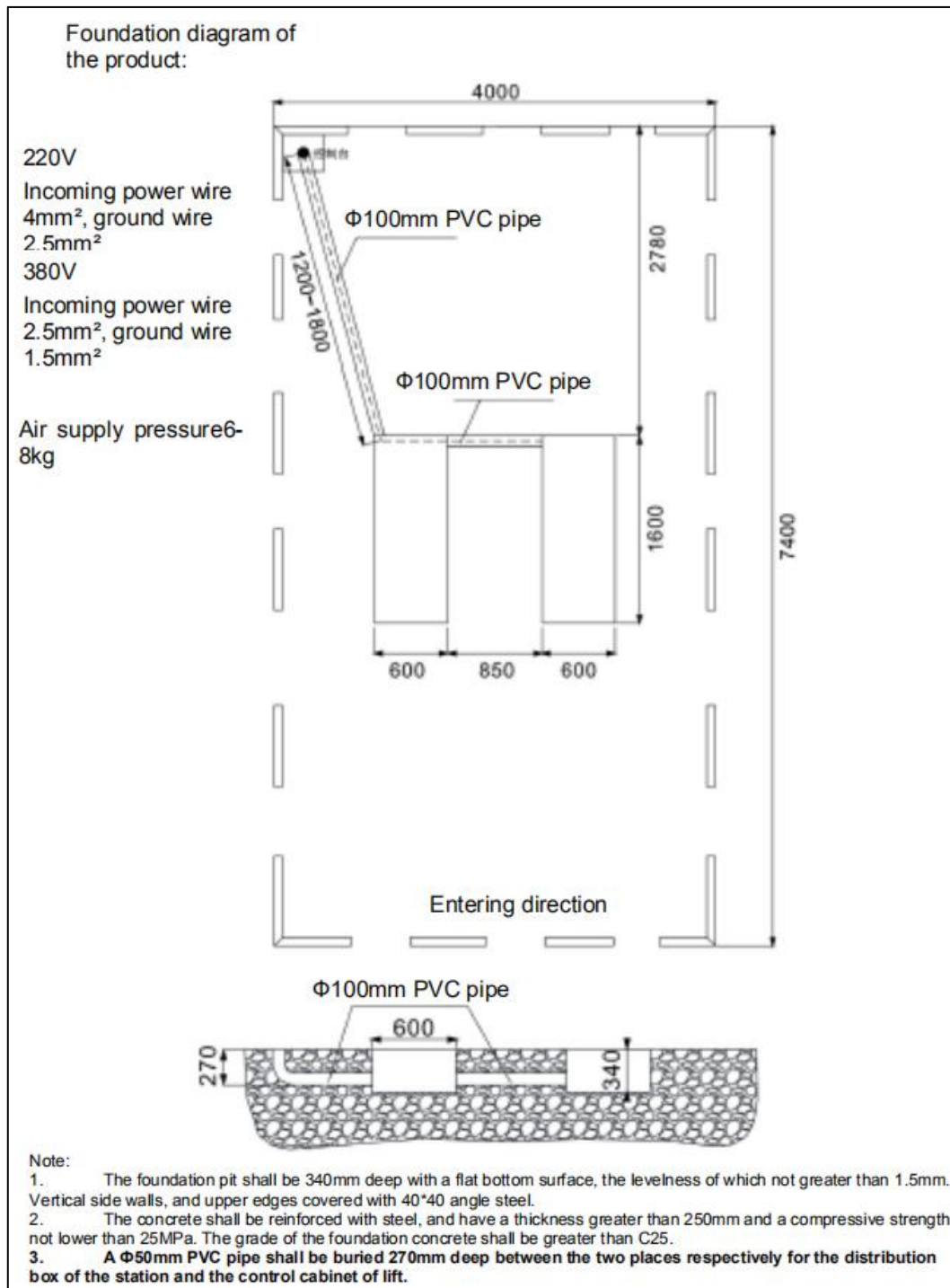

Fig. 5

Schematic diagram

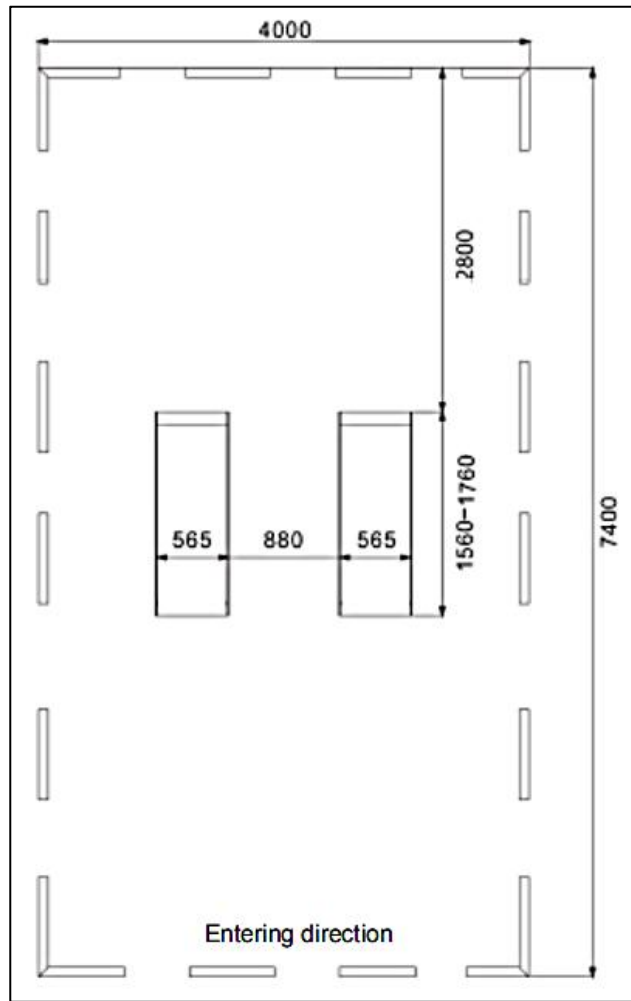

Fig. 6

Voltage	Power	Start Current	Operating Current	Wire size	Air switch	Applicable to
380V	3KW	21A-35A	8.5A	≥2.5mm ²	C63	Scissor lift
220V	3KW	60A	21A-25A	≥4mm ²	C63	Scissor lift
380V	2.2KW	18A-30A	7.5A	≥2.5mm ²	C63	Two posts, four posts
220V	2.2KW	60A	20A-22A	≥4mm ²	C63	Two posts, four posts

2.3 Installation



- Only professionals are allowed to conduct the installation work. Moreover, they shall read and follow the operation instructions below carefully to prevent machine damage or injuries.
- Only authorized technicians are allowed to install the lift.

2.3.1 Installation requirements

The lift must be installed in accordance with the specified safe distances from walls, columns and other equipment (as shown in Fig. 7), including the minimum distance 2000mm-2900mm from walls.

The ceiling height cannot be less than 4000mm. It is recommend to install the lift in a pit, and construct the foundation as required in Fig. 7.

Nevertheless, the lift can be installed on any indoor floor, provided that the floor meets the leveling requirements and has enough bearing capacity ($\geq 25\text{MPa}$).

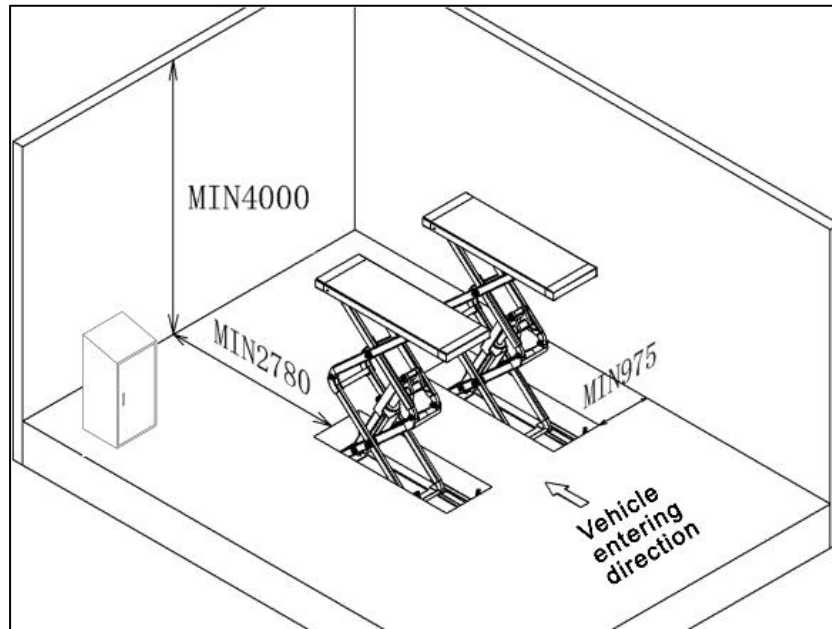

Fig. 7

The arrived goods shall be inspected for completeness before installation of scissor lift.

The movement and installation of the lift shall be carried out by the professionals.

For the transportation and storage of the machine, refer to the **Chapter 2.1**.

2.3.2 Installation of lifting platforms

Determine the installation direction of the lift according to the arrows on the lift package. When the lift is installed in the pit or on the ground, insert adjusting sizing blocks under the platform, lift the lifting platform with a forklift or other lifting equipment (Fig. 8) to about 1000MM, so as to ensure that the mechanical safety device is activated and locked.

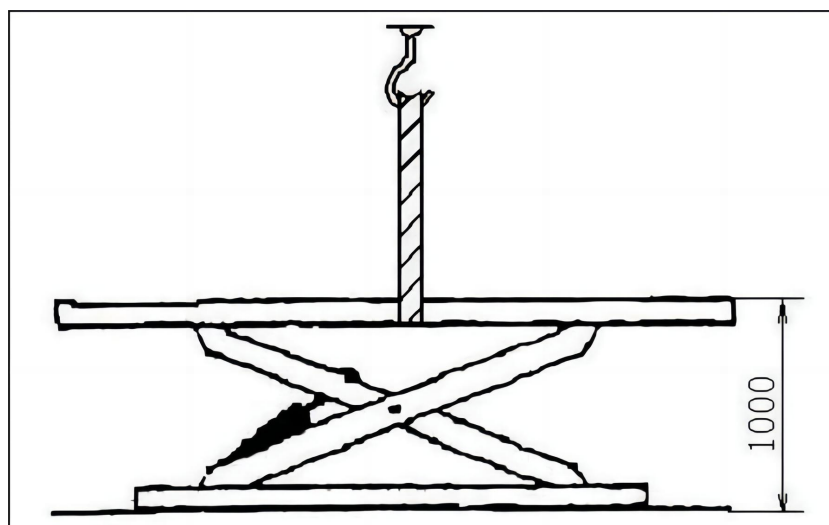

Fig. 8



- To avoid the failure of the mechanical safety device, a wood block can be inserted at the middle of the connecting rod. When the hydraulic system is not fully filled with hydraulic oil and has the lifting and lowering actions, do not work under the lift. Move the lifting platforms, adjust the distance between two platforms to make them parallel, and connect the electric circuit, oil circuit and pneumatic circuit as specified in the Electrical Diagram and Oil Circuit Connection Diagram.
- Only after the hydraulic system connection is completed, the pneumatic circuit connection can be conducted.
- Oil pipes, electric wires and air pipes shall not be damaged.
- Connection of electrical circuit: Connect the electrical circuit according to the wire diameter and wire size specified in the Electrical Diagram.

Only the professionals qualified for electrical operation are allowed to conduct the electrical installation.



- Open the upper cover of the control cabinet first.
- Connection of power line: Connect the 380V three-phase four-wire power line (cable of $3 \times 2.5\text{MM}^2 + 1 \times 1.5\text{MM}^2$) to the control cabinet interfaces U, V, W and input terminal, and connect the PE grounding wire to the labeled grounding bolt firstly and then to the labeled grounding bolts at the bottom of the two platforms (Fig. 9, 10).

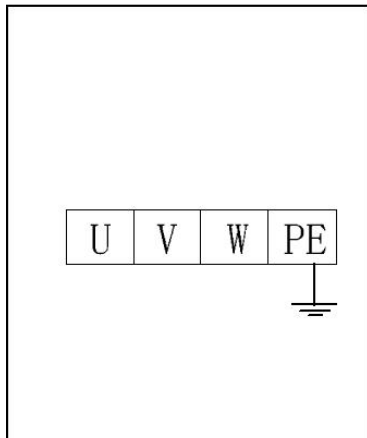

Fig. 9

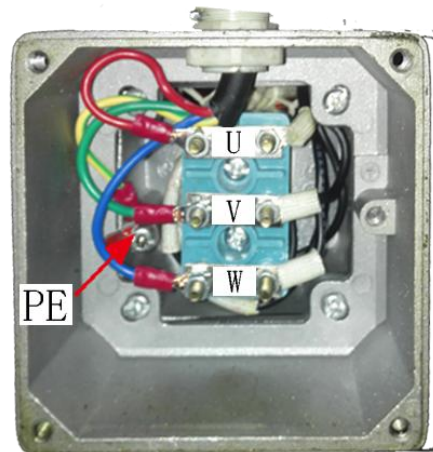

Fig. 10

Connection schematic diagram of air pipe joint:

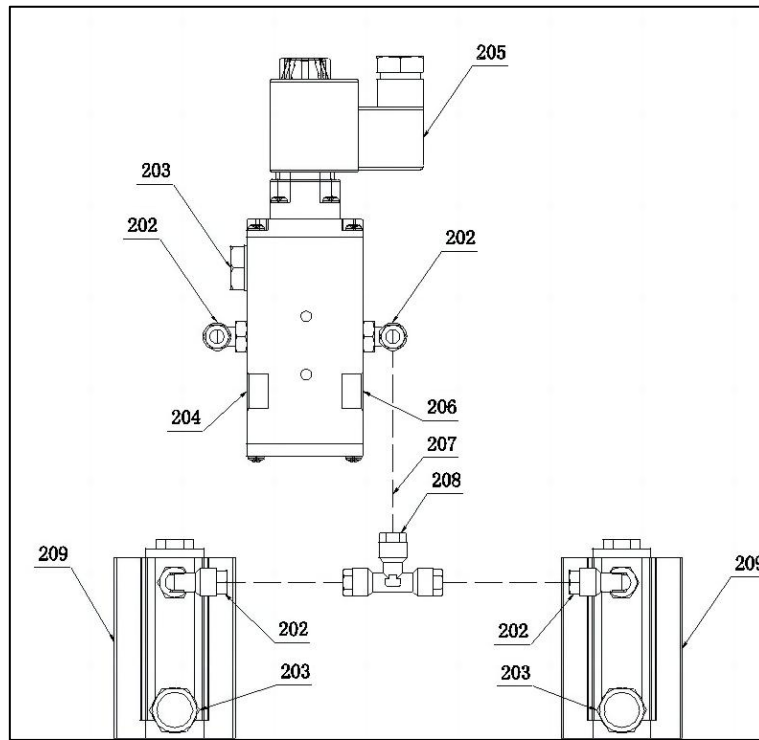
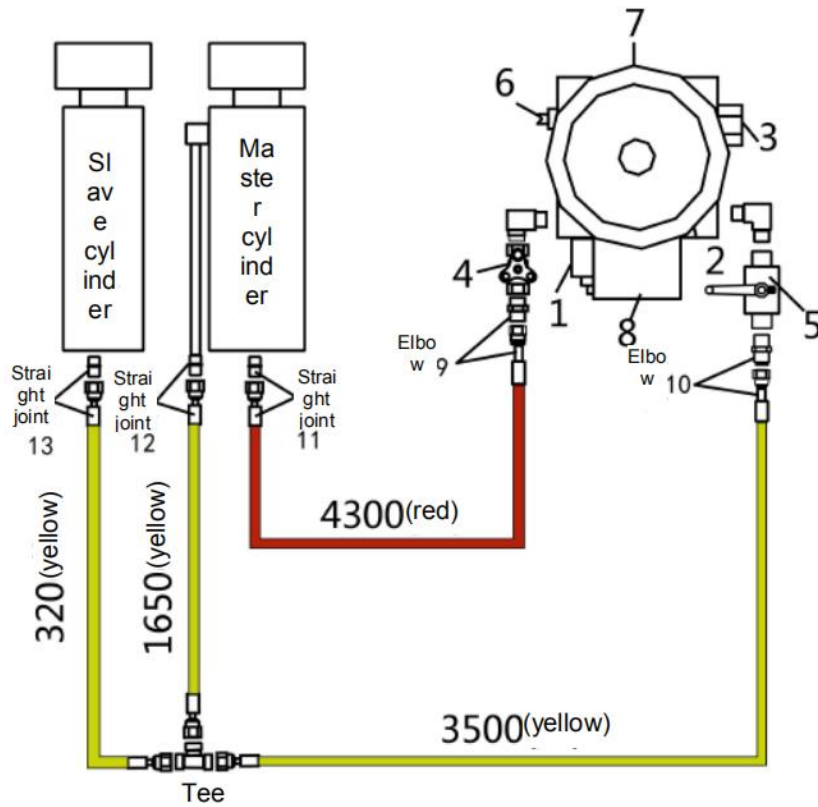

Fig. 11

S/N	Part No.	Quantity	S/N	Part No.	Quantity
203	Muffle	3	207	Air pipe PU0604	1
204	Plug 1/8	1	208	T-joint APE	1
205	Solenoid valve	1	209	Small cylinder	2
206	Plug 1/4	1	211	Air pipe PU0806	

Schematic diagram of oil pipe joint:



In case of working, 4 is opened and 5 is closed.

In case of oil filling, 4 is closed and 5 is opened.

1	Oil return solenoid valve	5	Oil-filling valve
2	Check valve	6	Lowering speed regulating valve
3	Relief valve	7	Motor
4	Service valve	8	Motor box

Fig. 12

Hydraulic schematic diagram:

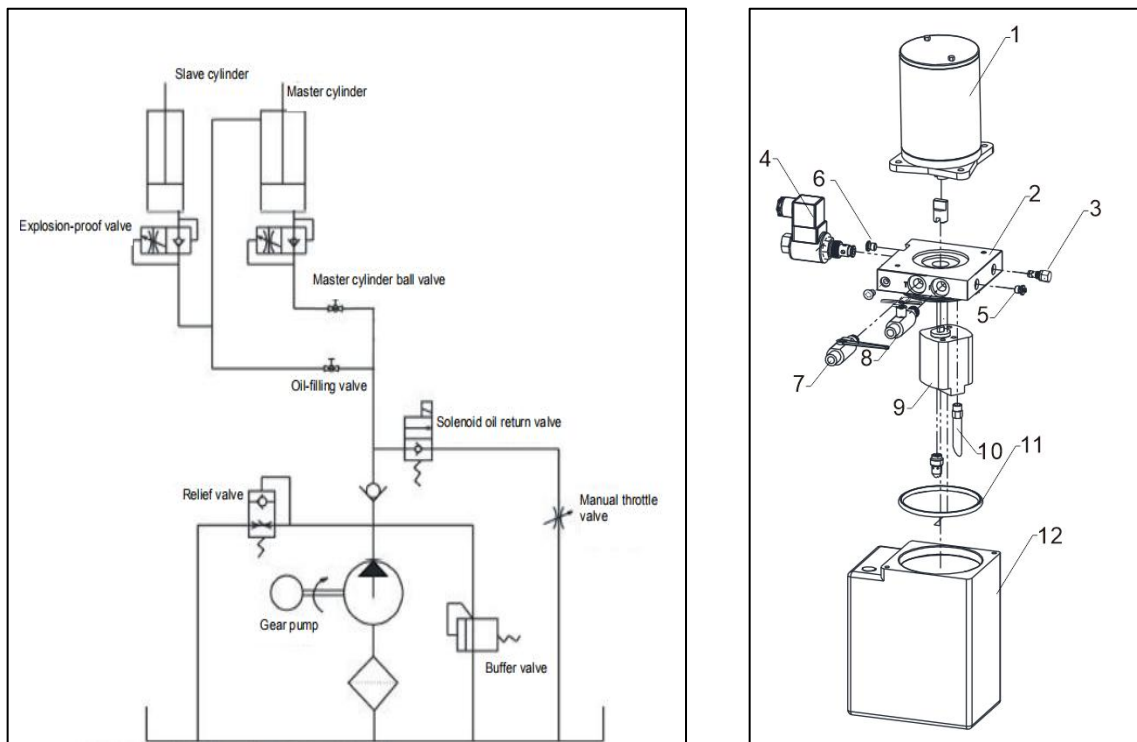

Fig. 13

Explosion-proof valve: used to significantly reduce the speed of lowering after the blowout of oil pipe.

Oil-filling valve: used to adjust the amount of oil in the slave cylinder. **(NO.7)**

Solenoid oil return valve: controlling the oil circuit for lowering. **(NO.4)**

Manual throttle valve: adjusting the speed of lowering. **(NO.5)**

Relief valve: controlling the maximum pressure. **(NO.3)**

Gear pump: supplying oil pressure. **(NO.8)**

Buffer valve: reducing the motor load when the motor starts. **(NO.9)**

3. Commissioning

- (1) **Filling of hydraulic oil:** Open the door of the control cabinet and fill the hydraulic tank with 16L 46# anti-wear and antifreezing hydraulic oil (provided by the user) with a funnel.
 - (2) **Pipeline connection:** Connect the oil pipe according to Oil Circuit Connection Diagram (the protection of the joint is the most critical during the process of connecting the oil pipe, and prevent the sand from entering the oil circuit).
 - (3) **Oil-filling and leveling:** Turn on the power, press the **UP** button, check whether the motor runs in the correct direction, and finally fill oil and perform bleeding and leveling.
 - (4) **Installation and leveling:** Lock the safety jaws in the safety teeth of the same level, adjust the spacing, fix the expansion screw (not installing the core), and after rough leveling, install the expansion screw core, and then perform fine leveling.
- Insert metallic sizing blocks under the platform to avoid the horizontal leveling of the lift on the uneven ground.

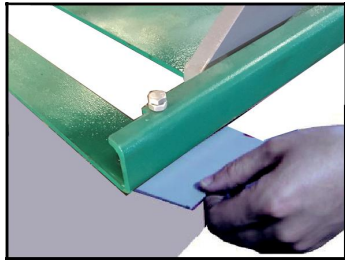

Fig. 14



Fig. 15

- Drive a $\Phi 18$ percussion bit to 160 mm depth in the ground from the holes on the baseplate with an electric hammer (Fig. 16), and clean the hole.
- Fix anchor bolts into the holes with a light hammer (without inserting the central expansion screws of the anchor bolts, which shall be fixed after the leveling is completed), as shown in Fig. 17.

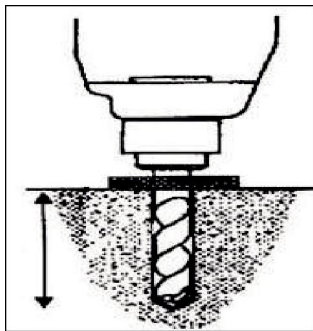

Fig. 16

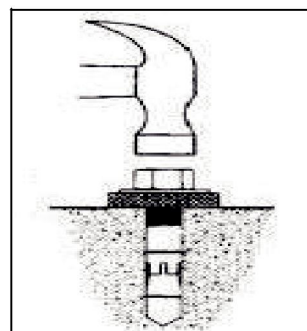

Fig. 17

- Lift the platforms to the fifth or sixth teeth, then press the **Lock** button to fasten the safety jaws of the left and right platforms into the safety gear racks firmly.
- Inspect that the surfaces of the left and right platforms are level laterally and longitudinally with a transparent leveling pipe or level gauge (Fig. 18).

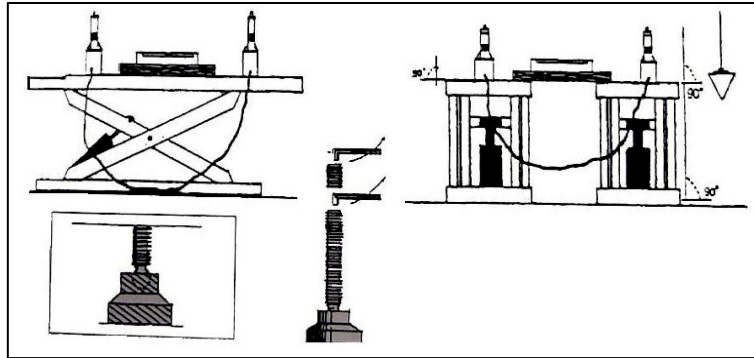

Fig. 18

If the uneven platform is caused by the uneven foundation, adjust the adjusting bolts (Fig. 19) on the baseplate of the main lift with a wrench.

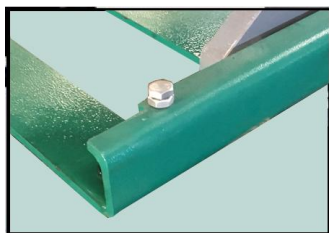

Fig. 19

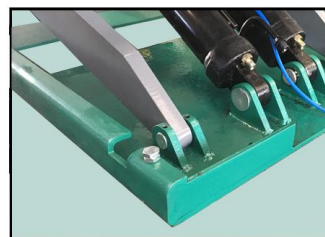

Fig. 20



- After the leveling, insert the central expansion screws of foundation bolts, and fix the expansion screws with a heavy hammer.
- Tighten the nuts of the foundation bolts.
- Loosen the tightening nut first.
- Adjust the length of the supporting screw rod to the proper position.
- Then tighten the nut.

(5) **Trial loading:** After verifying that all the above operations are normal, drive a vehicle onto the lift and carry out trial loading, and if the result is normal, the lift can be put into normal use.

4. Maintenance

4.1 Maintenance

- Add oil at all shaft crossovers in the machine once a month.
- Keep the safety gear rack clean.
- Keep the upper and lower pulleys clean and lubricate them.
- Change the hydraulic oil once a year.
- Remove the waste in the tank.
- The compressed air pressure used for pneumatic unlocking of the safety lock is 6-8kg/cm², which ensures the normal operation of the pneumatic solenoid valve.

4.2 Operation cautions

- Before working, please make sure there are no foreign objects around or under the machine.

- During raising and lowering, no one can stand on the left or right of the lift or stand on or below the lift and no one can sit in the vehicle on the lift.
- Do not lift the vehicle that exceed the lifting capacity of the lift.
- During raising and lowering, apply the parking brake of the vehicle and place the rubber pads.
- During maintenance, “lock” the main and sub lifts in the safety teeth of the same level (press the **Lock** button).
- Always observe if the lift platforms act synchronously during raising and lowering. Shut down the machine in time if any abnormality is found, and restart the machine only after inspection and troubleshooting.
- If the **DOWN** button is pressed, the lift will be immediately lowered, then the safety jaw cylinder will be immediately opened due to the energized pneumatic solenoid valve, and the safety jaw will be immediately lifted. Therefore, during the lowering operation, be sure to raise the lift slightly so that the safety jaw and safety gear rack can be disengaged from each other, and then press the **DOWN** button to lower the lift.
- If the machine has not been used for a long time, inspect it before use.

4.3 Electrical operation instructions

UP :

Press the **UP** button and the lift will rise immediately. At this point, the motor will start to run immediately, and the safety jaw cylinder will lift the safety jaw due to the energized pneumatic solenoid valve that opens the pneumatic circuit. When the UP button is released, the motor will stop running, the lift will immediately stop rising, and the safety jaw will fall on the safety gear rack due to the deenergized pneumatic solenoid valve that closes the pneumatic circuit.

DOWN :

Press the **DOWN** button and the lift will be lowered immediately, and the safety jaw cylinder will lift the safety jaw due to the energized pneumatic solenoid valve that opens the pneumatic circuit.

LOCK :



Press the **LOCK** button and the lift will be lowered immediately, and the safety jaw cylinder will not lift the safety jaw because the pneumatic solenoid valve is not energized, and the lift will be locked by the safety gear rack to enhance the safety of the operation.

4.4 Oil-filling and leveling

When the lift is used after installation and adjustment, the air in the cylinder is not completely discharged, and the hydraulic oil is naturally lost or leaks. This may cause the right platform to be lower than the left platform (seen from the front of the vehicle) after the use for a period of time. At this point, follow the steps below:

Adjustment of small platform scissor lift

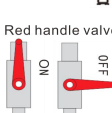
Make sure the motor turn in anticlockwise direction.
 Make sure red handle valve close, club valve on.
 Make sure connection oil cylinder is correct.
 Make sure the air lock work.
 Identify main cylinder and sub cylinder

We suggest to use ISO-L-HM46(antifreeze type).
 If the temperature below -10°, we suggest to use ISO-L-HM32(antifreeze type).

Two post lift——10L
 Ingrounded small scissor lift——14L
 Ongrounded small scissor lift——14L
 Ongrounded double level scissor lift——16L
 Ingrounded double level scissor lift——16L

Replace the oil in the first year.
 Replace the oil ever two year except the first year.

sub cylinder can't be higher than a main cylinder at anytime.

1. Push the red buttons in the middle and turn in clockwise direction, the safety will be unlocked and keeping. (The button is beside the motor)



2. Make sure club valve open, and then press "up" button to raise the main cylinder 1m high.

Do not raise the main cylinder to the toppest level.

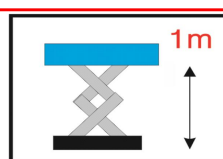

3. Turn on the red handle valve.



4. Turn off the club valve.



5. Press "up" button to raise the sub-cylinder until it is at the level of the main cylinder. Press "lock" button to lower the sub-cylinder to the bottom. (Repeat 3 times.)

Make sure the sub-cylinder can not higher than main cylinder at any time.

主机不动 副机来回升降3次



副机举升高度请勿超过主机

6. Press "up" button to make the sub-cylinder raise at the level of the main cylinder.

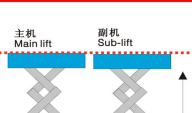

7. Turn off the red handle valve.

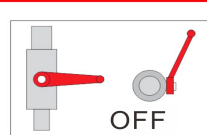

8. Turn on the club valve.



9. Press the red button and turn. Let the red button bounce. At this time the mechanical safety can be locked.



Fig. 21

4.5 Emergency manual lowering procedures at power failure

Lift the safety jaws above the cylinders for both platforms and put paper blocks under the safety jaws to separate them from the gear racks. Switch off the power and open the control cabinet door to locate the oil return solenoid valve. Loosen the copper cap at the end of the solenoid valve (2) so that the platforms can be lowered. When the platforms have been lowered, tighten the copper cap at the end of oil return solenoid valve timely to avoid unnecessary trouble. Otherwise, the hydraulic oil will directly return to the tank and thus cannot drive the cylinders to raise the lifts when the voltage is supplied normally for raising. Manual lowering is not recommended unless in case of emergency.



- Troubleshooting must be conducted by trained and experienced technicians.
- Fault symptoms and troubleshooting methods.

Fault symptom	Cause	Troubleshooting method
The motor does not rotate when the UP button is pressed.	① The power supply is abnormal	Perform inspection and troubleshooting, and connect the electric wires.
	② The AC contactor of the pump motor main circuit does not pull in.	The motor will run if the contactor is pressed with an insulating rod forcibly. Inspect the control circuit, and replace the contactor if the voltage at the contactor coil terminal is normal.
	③Phase loss.	Use a multimeter to check if the three phases are 380V. Note: A tester can not be used to check if the phase is lost.
	④ The button switch is faulty.	Inspect the button contracts and wires and perform troubleshooting.
The motor rotates but the platform does not rise when the UP button is pressed.	① The motor rotates reversely.	Exchange the phase sequence of the incoming power wires.
	② The platform ascends with light load but does not ascend with heavy load.	Increase the safe pressure setting of the relief valve by rightward rotating the valve slightly. If there is dirt in the valve core of the lowering solenoid valve, clean the valve core.
	③ The hydraulic oil is insufficient or the grade is incorrect.	Refill or change the hydraulic oil.
	④ The manual oil drain plug of the solenoid valve is not tightened.	Tighten the oil drain plug of the main lift or sub lift.
	⑤ The solenoid valve connector is blown.	Replace the solenoid valve connector of the main lift or the sub lift.
The lift does not descend when the DOWN button is pressed.	① The safety jaw is not separated from the safety gear rack.	Extend the delay time of the time delay slightly.
	② The safety jaw is not uplifted.	The air pressure is insufficient, the safety jaw gets stuck or the air pipe is broken. Adjust the pressure of the air compressor, inspect the air pipe and perform troubleshooting.
	③ The pneumatic solenoid valve does not work.	If the pneumatic circuit is blocked for the energized pneumatic solenoid valve does not work, inspect or replace the pneumatic solenoid valve.
	④ The lowering solenoid valve does not work.	Inspect the connector and coil of the lowering solenoid valve and inspect whether the copper nut at the end of solenoid valve is rightward tightened.
	⑤ The explosion-proof valve is blocked.	Remove the "explosion-proof valve" from the oil inlet port at the cylinder bottom of main lift or sub lift cylinders, and clean explosion-proof valve.
The lift descends slowly with normal load.	① The hydraulic oil is too viscous or frozen and deteriorated (in winter).	Change the hydraulic oil or increase the room temperature according to the instruction.
	② The "explosion-proof valve" preventing the blowout of the oil pipe is blocked.	Remove or close the intake pipe to lock the safety jaw without lifting, remove the "explosion-proof valve" from the oil inlet port at the bottom of the oil cylinder and clean it.
The left and right platforms are out of sync and not at the same height.	① The air in the oil cylinder is not bled completely.	Refer to the procedures for oil filling and leveling.
	② The oil pipe or joint leaks oil.	Tighten the joint or replace the oil seal, and then fill oil and perform leveling.
	③ The "oil filling shutoff valve" can not be closed tightly, and therefore oil filling is required almost everyday.	Replace the oil filling shutoff valve, and then fill oil and perform leveling.
There is noise during raising and lowering.	① Insufficient lubrication.	Apply oil at all hinges and moving parts (including piston rods) to lubricate them.
	② The foundation or the machine is distorted.	Readjust the machine to make it level and fill (pad) the foundation.
The platform always rises when the Down button is pressed.	① The time relay is loose or damaged.	Reinsert or replace the time relay.

7	Hinged shaft circlip of upper and lower scissor arms	26	Hexagon socket screw with round head
8	Upper sliding block	27	Lower outer scissor arm
9	Upper and lower hinged shafts of scissor arm	28	Upper outer scissor arm
10	Safety gear rack	29	Upper cover of safety device
11	Inner scissor arm lower hinged shaft oilless bearing	30	Cylinder
12	Lower scissor arm center hinged shaft oilless bearing	31	Hexagon socket screw with round head
13	Upper scissor arm center hinged shaft oilless bearing	32	Upper inner scissor arm
14	Oil cylinder bottom shaft oilless bearing	33	Lower inner scissor arm
15	Safety device upper cover oilless bearing	34	Lower hinged shaft of small scissor cylinder
16	Hinged shaft circlip of piston rod of small scissor	35	Cylinder cover plate screw
17	Lower hinged shaft circlip of small scissor cylinder	36	Master cylinder
18	Lower sliding block of small scissor	37	Slave cylinder
19	Hinged shaft spacer sleeve of upper and lower scissor arms	38	Oil cylinder cover plate

Warranty

THIS WARRANTY IS EXPRESSLY LIMITED TO PERSONS WHO PURCHASE SMARTSAFE PRODUCTS FOR PURPOSES OF RESALE OR USE IN THE ORDINARY COURSE OF THE BUYER'S BUSINESS.

SMARTSAFE electronic product is warranted against defects in materials and workmanship for one year from date of delivery to the user.

This warranty does not cover any part that has been abused, altered, used for a purpose other than for which it was intended, or used in a manner inconsistent with instructions regarding use. The exclusive remedy for any automotive meter found to be defective is repair or replacement, and SMARTSAFE shall not be liable for any consequential or incidental damages.

Final determination of defects shall be made by SMARTSAFE in accordance with procedures established by SMARTSAFE. No agent, employee, or representative of SMARTSAFE has any authority to bind SMARTSAFE to any affirmation, representation, or warranty concerning SMARTSAFE automotive meters, except as stated herein.

Disclaimer

The above warranty is in lieu of any other warranty, expressed or implied, including any warranty of merchantability or fitness for a particular purpose.

Purchase Order

Replaceable and optional parts can be ordered directly from your SMARTSAFE authorized dealer. Your order should include the following information:

- Order quantity
- Part number
- Part name

Statement:

SMARTSAFE reserves the rights to make any change to product designs and specifications without notice. The actual object may differ a little from the descriptions in the manual in physical appearance, color and configuration. We have tried our best to make the descriptions and illustrations in the manual as accurate as possible, and defects are inevitable, if you have any question, please contact local dealer or after-sale service center of SMARTSAFE, SMARTSAFE does not bear any responsibility arising from misunderstandings.



Shenzhen Smartsafe Tech Co.,Ltd.



+86-755-89589810



www.newsmartsafe.com



3310, Building 11, Tian'an Cloud Park, Bantian Street,
Longgang District, Shenzhen,Guangdong, China