

Applications

Make	Model	Years
Audi	A1/A1 Sportback	2012-2016
	A3 Cabrio	
	A3 Saloon	
	A3/A3 Sportback	
	Q3	
Seat	Ibiza	TSI ACT
Volkswagen	Golf VII	TSI ACT
	Passat	Blue GT
	Polo	

Engine Code

1.4	CPTA, CZEA
-----	------------

LASER[®]

6554

Camshaft Alignment Kit VAG 1.4 TFSi



Guarantee

If this product fails through faulty materials or workmanship, contact our service department direct on: **+44 (0) 1926 818186**. Normal wear and tear are excluded as are consumable items and abuse.



Distributed by The Tool Connection Ltd

Kineton Road, Southam, Warwickshire CV47 0DR
T +44 (0) 1926 815000 F +44 (0) 1926 815888
info@toolconnection.co.uk www.toolconnection.co.uk



- Application: VAG 1.4 TFSi petrol engines - Code CPTA,CZEA 2012-16 Audi A1/Sportback, A3 Cabrio/Saloon, A3/A3 Sportback, Q3 Seat Ibiza and Volkswagen Golf V11, Passat and Polo.
- Kit includes: C734 Camshaft positioning tool (OEM T10504), C735 Stepped pin - short (OEM T10504/1), C439 Crankshaft locking pin (OEM T10340) C736 Stepped Pin - Long (OEM T10504/2).

6554 - Camshaft Alignment Kit

- From 2012 the Volkswagen Audi group of companies introduced a new version of their 1.4 TFSi petrol engine. This new engine is equipped with CoD technology (Cylinder on Demand) which allows the engine to switch between 2 and 4 cylinder running modes to maximise efficiency.
- The new engine design has also meant the need for new camshaft locking tools.
- The Laser 6554 provides the essential tools required to set and time the main engine components when replacing the camshaft drive belt. Because the 6554 only contains those tools deemed as essential some users may need to consider additional tooling such as generic pulley/sprocket holding tools.
- The following instructions are for guidance only. Please refer to OEM derived data such as the vehicles manufactures own data or Autodata.
- The use of these engine timing tools is the user's responsibility and Tool Connection cannot be held liable for any damage caused what so ever.

Components

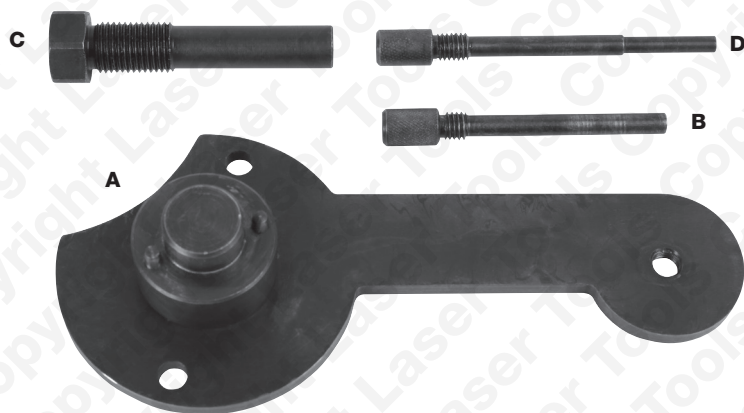

Ref	Code	OEM Number	Description
A	C734	T10504	Camshaft Positioning Tool
B	C735	T10504/1	Camshaft Timing Pin
C	C439	T10340	Crankshaft Timing Pin
D	C736	T10504/2	Camshaft Timing Check Pin

Timing Belt Numbers

Bosch	Contitech	Dayco
1 987 949 684	CT1167	163RP7M200HT

Instructions



Note: Timing set with engine at TDC No.1

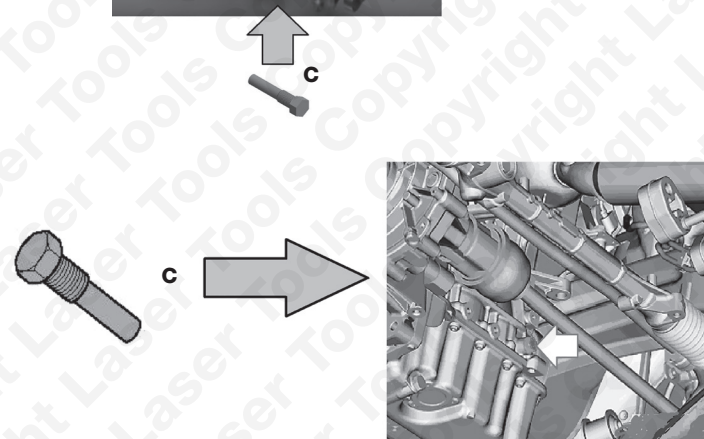
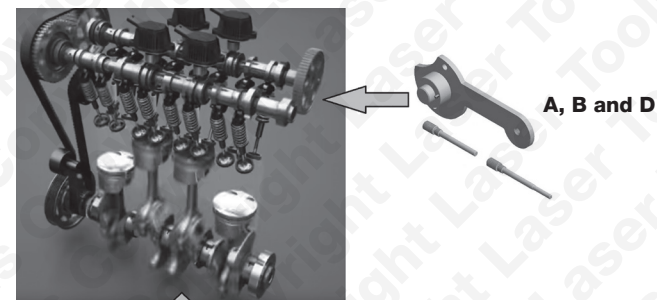

A, B and D = Used to set the camshaft timed position on rear of camshafts (gearbox end of engine).

